

INSTALLATION, OPERATION AND MAINTENANCE MANUAL

BS 1868/API 594 CAST STEEL SWING CHECK VALVE

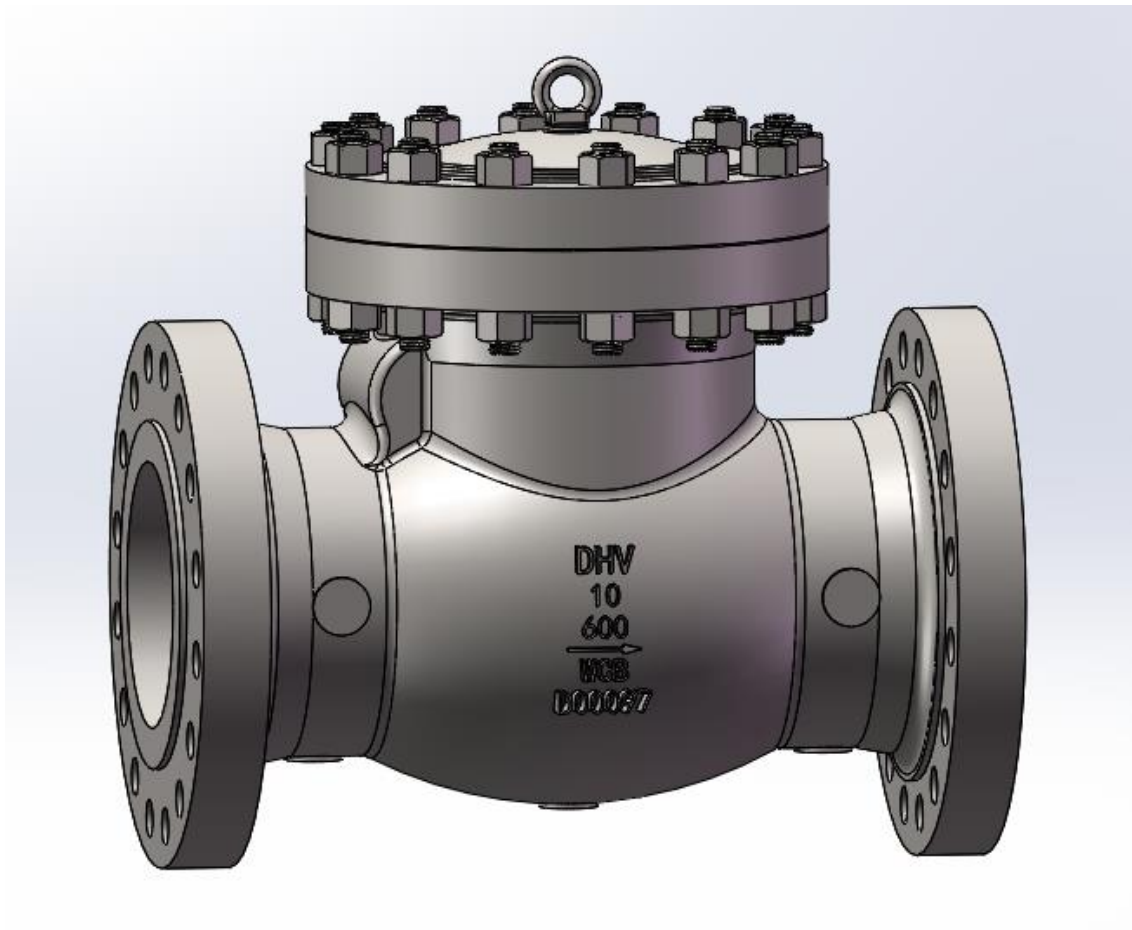

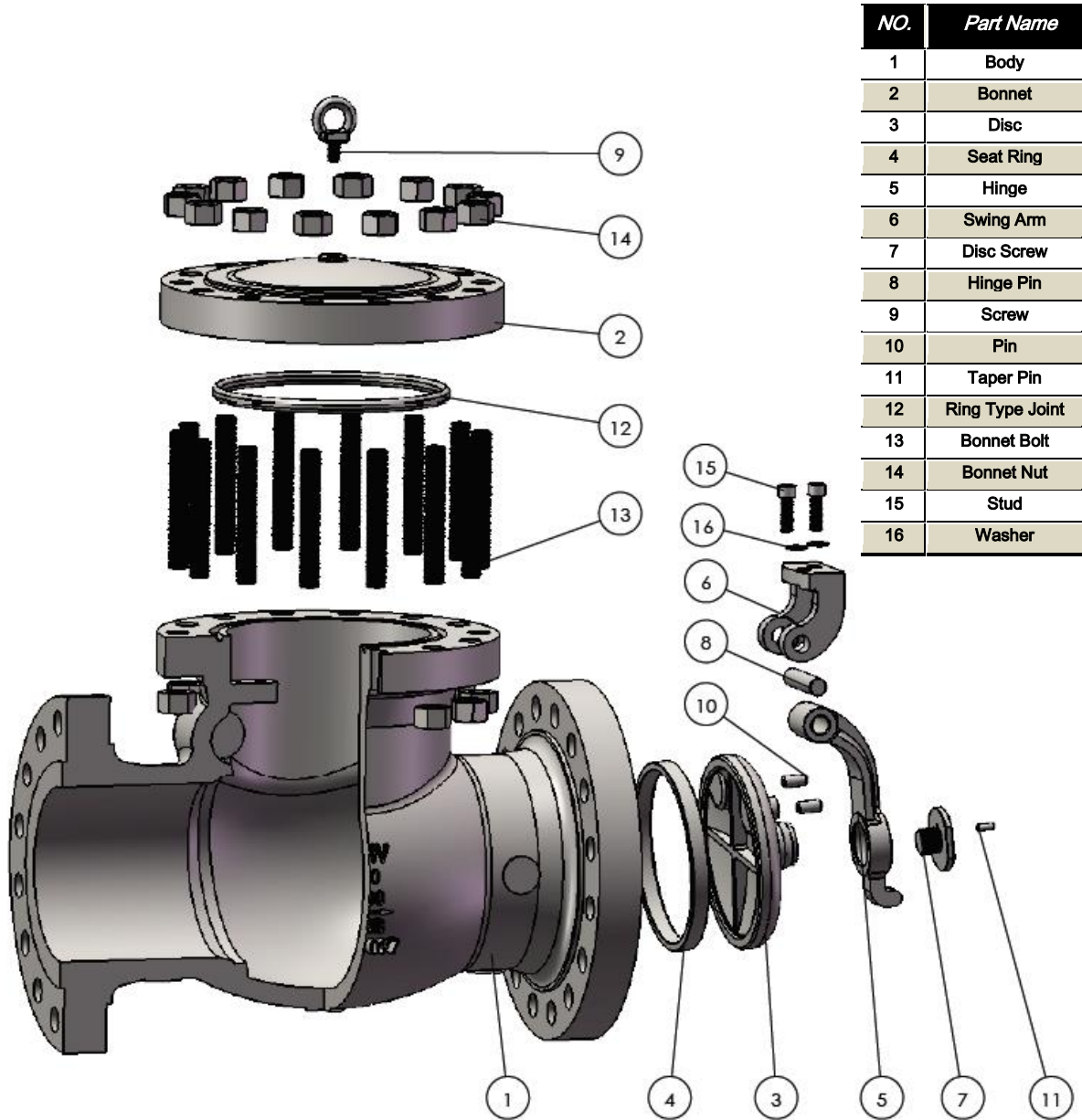

TABLE OF CONTENTS

FOREWORD	4
1. ENDUSER INSTRUCTION	4
2. VALVE TRANSPORTATION AND STORAGE	5
2.1 TRANSPORTATION	5
2.2 STORAGE	5
3. VALVE INSTALLATION	6
3.1 INSPECTION BEFORE INSTALLATION	6
3.2 INSTALLATION.....	6
4. VALVE OPERATION	10
5. VALVE MAINTENANCE	12
6. DETAILED DISASSEMBLY AND ASSEMBLY	13
6.1 BOLTED BONNET CHECK VALVE DISASSEMBLY.....	13
6.2 BOLTED BONNET CHECK VALVE ASSEMBLY	13
7. TROUBLESHOOTING	14
8. WARRANTY AND SERVICE	15
8.1 VALVE WARRANTY PERIOD.....	15
8.2 SERVICE	15

TYPICAL CONFIGURATION

BS 1868/API 594 CAST STEEL SWING CHECK VALVE



NO.	Part Name
1	Body
2	Bonnet
3	Disc
4	Seat Ring
5	Hinge
6	Swing Arm
7	Disc Screw
8	Hinge Pin
9	Screw
10	Pin
11	Taper Pin
12	Ring Type Joint
13	Bonnet Bolt
14	Bonnet Nut
15	Stud
16	Washer



FOREWORD

Personal Safety and Long Term Ownership of your DHV BS 1868/API 594 Swing Check Valve is the most important matter in reviewing our Installation, Operation & Maintenance Manual. This manual will provide all the necessary safety guidelines for our valve including information for the valve transportation, storage, installation, operation and maintenance. Please read carefully before installing or servicing the valve.

DHV provides general guidelines in this manual, and cannot provide specific data and warnings for all possible applications. The purchaser/end user must therefore assume responsibility for proper valve selection, sizing, installation, operation, and maintenance of DHV valve products. The purchaser/end user should read and understand this document and any instructions provided with the product, and conduct training with its employees and contractors to ensure they are aware of the proper and safe use of DHV valve products in connection with the specific application.

1. ENDUSER INSTRUCTION

Personnel safety is always the most important factor in the transportation, storage, installation, operation and maintenance of any valve. DHV valves are designed to meet the customer's order requirements and specifications. DHV disclaims all responsibility for problems that may be caused by applications other than the specified use. Valve service pressure/temperature information is detailed on the valve name plate. When selecting a valve, always consider the application, service and temperature for the intended service. Select the applicable valve material for anti-corrosion and anti-abrasive service. For safety of personnel and plant/environment: Prior to conducting any service on the valve, ensure the valve is not under pressure, properly vented, and drained. When performing any operation, maintenance or service, personal protective equipment should be used, such as protective clothing, oxygen masks, safety glasses, work gloves, etc. DHV will not be responsible for any loss or expense resulting from the failure of equipment, damage to any property, or death or injury to any person resulting in whole or in part from repairs or modification performed by other than authorized DHV personnel. Such unauthorized repairs shall also serve to terminate any contractual or other warranty, if any, on the equipment and may result in the equipment no longer meeting applicable requirements.



2. VALVE TRANSPORTATION AND STORAGE

2.1 TRANSPORTATION

1. Package in the upright position, the disc of check valve shall be fixed with a support when packaging. Each valve should be securely packaged either on a pallet or in a crate to avoid any damage during shipping.
Place a “Before installation, please remove wooden stopper” sticker on the flange protector.
2. Use the proper hoisting equipment to transport the valve, especially when lifting or lowering the valve. Special attention to personnel safety and the care of the valve should be made when transporting the valve. Avoid impacting or striking the valve during transportation. Lay the valve on a clean flat surface; avoid laying the valve on the flange face. Ensure there is adequate clearance around the valve for proper operation and maintenance.
When lifting the valve, use the lifting eye.
3. During transportation, ensure the valve’s paint, name plate and flange sealing surfaces are fully protected. Do not drag the valve across the floor, or place the valve flange sealing face on the floor.
4. For those valves not required to be immediately installed, do not open the end flange protective covers. Ensure the valves are stored in a safe, clean environment and are protected from rain and dust.

2.2 STORAGE

1. Valves should be stored in the closed position. Valve ports and flange serration surfaces should be kept sealed with protective flange covers.
2. Valves should be stored in a dust free, low humidity and well-ventilated room, not in direct contact to the floor. If possible, the valves shall be kept in the original packing box. If the valves must be stored outdoors, keep the valve in the original crate or shipping container. Ensure the valve’s packaging is stored on raised blocking to avoid moisture damage. Protective covering should be used for protection against dust and rain.
3. Valves should never be stacked on top of each other, to avoid any valve distortion which may affect valve performance and cause personnel injury.
4. Valves that have been stored for an extended time should be cleaned and inspected prior to installation. Inspect the sealing surface to ensure it is clean and free of any debris or damage.
5. Do not expose the valve to any corrosive environment.

3. VALVE INSTALLATION

- Review all documentation to fully understand the valve and related information that will provide safe installation and a long service life for your valve.
- Valve information can be found on the valve body, and the name plate. Fig 1 is a typical nameplate.
- Valve ends should have a protective cover to protect the valve bore from any foreign particles and dust which will damage the disc and seat sealing surfaces.

Figure 1 Typical Valve Nameplate

SIZE	Nominal Valve Size
CLASS	Pressure Class
FIG NO.	Figure NO. See DHV's Catalog
S/N NO.	Valve Series Number
BODY	Body Material
STEM	Stem Material
DISC	Disc Material
SEAT	Seat & Seat Insert Material
psi at °F	Pressure-temperature Rating
DATE	Manufacture Date

Nameplate Information

3.1 INSPECTION BEFORE INSTALLATION

3.1.1 Before installation, check the valve name plate and valve body information to ensure the valve is suitable for the intended service.

3.1.2 Before installation, remove the flange cover and the protective film on the flange sealing face, and disc support, inspect the bore and the flange sealing surface, remove any dirt with clean soft cloth, use an anti-corrosive cleaning liquid to clean if necessary, and never use any other chemical products.

3.1.3 Inspect the flange gasket (including ring gasket) sealing surface and ensure it is in acceptable condition for installation.

3.2 INSTALLATION

3.2.1 Position the valve into the pipe or the flange connection; ensure that any stress caused by improper pipe alignment is relieved first. Valves are not intended to be a means of aligning improperly fitted pipe.

3.2.2 Valves marked with flow direction must be installed in line with the piping flow.

3.2.3 Valve should be installed in a horizontal position with the center of the valve.



FLANGE ENDS:

- Select the proper gasket (including ring gasket) to install, line up the bolt holes between the valve flange and pipeline flange, then install the bolts and nuts and tighten to the accepted piping and bolting standards. The bolt threads should be lubricated first for ease of bolting.
- Use an appropriate sized torque wrench when tightening the bolt/nut, to avoid flange deformation. Please follow Fig 2 and Table 1 for bolting sequence and bolting torque. If the bolting quantity is different from the chart shown, please follow the same principle to get a new sequence to follow.
- For large diameter valves, the valve must be properly and safely supported during installation. After installation is completed, valve supports should be moved to the bottom of the valve flanges.
- After valve installation is complete, recheck and tighten the bolts as necessary to the values provided in Table 1 & Figure 2.
- It is recommended that the tightness of the joint bolt tension be inspected at least yearly. Refer to Table 1 & Figure 2.



WARNING: DURING INSTALLATION, IF VALVE IS NOT IN LINE WITH THE PIPELINE, FLANGE FACES ARE NOT PARALLEL TO EACH OTHER, OR BOLTING TORQUE IS NOT UNIFORM, VALVE LEAKAGE MAY BE EXPERIENCED.

Table 1 Bolting Tightening Torque Chart

Stud Size (Inch)	Measurement: Newton-meters N·m Tolerance: +/- 10% (Conversion: 1 ft·lb= 1.36 N·m 1 N·m = .74 ft·lb)						
	B7M/L7M	B7/L7	B8 (I)/ B8M(I)	B8M (II)	B8 (II)	B8MLCuN	B16
5/16-18UNC	21	27	8	25	26	9	28
3/8-16UNC	36	47	13	43	45	16	48
1/2-13UNC	85	111	32	101	107	37	112
9/16-12UNC	121	158	45	144	152	53	160
5/8-11UNC	165	217	62	197	208	72	218
3/4-10UNC	289	378	108	344	362	126	380
7/8-9UNC	459	601	171	459	-	200	605
1-8UNC	683	894	255	683	-	298	901
1-1/8-8UN	992	1298	370	811	-	433	1308
1-1/4-8UN	1381	1807	515	1130	-	602	1820
1-3/8-8UN	1860	2435	693	1167	-	812	2452
1-1/2-8UN	2438	3192	909	1530	-	1064	3214
1-5/8-8UN	3126	4092	1165	-	-	1364	4120
1-3/4-8UN	3931	5146	1465	-	-	1715	5182
1-7/8-8UN	4863	6367	1813	-	-	2122	6411
2-8UN	5933	7767	2211	-	-	2589	7820
2-1/4-8UN	8519	11152	3175	-	-	3717	11229
2-1/2-8UN	11764	15400	4385	-	-	5133	15507
2-3/4-8UN	15742	18747	5867	-	-	6869	18747
3-8UN	20528	24447	7651	-	-	8958	24447



WELD ENDS:

- Weld ends must be kept clean with no burrs, oil, dirt or foreign objects.
- The valve end and pipe end must be in proper alignment for effective welding.
- Follow the approved WPS to perform the welding. During welding, insure the temperature near the seat area does not overheat which will cause sealing area distortion. Protect the valve bore area to prevent welding slag and foreign matter from entering the valve.
- After welding, use approved and proper Non-Destructive Testing (NDT) method to check the welds; clean the welds thoroughly, and then perform local heat treatment if required.
- When installation is complete, and prior to system testing and start-up, clean the valve by flushing the line of debris and other materials that may have accumulated inside the valve and in the valve seating area and surfaces during construction. When flushing the valve, open the valve fully, flush for a determined time based on line size. Close the valve and allow fluid to fill the line, while opening and closing the valve while flushing. Fully close the valve, if seat leakage is noted after flushing, repeat flushing procedure. If leakage from the seat is still evident, the seating surface maybe damaged and need repair.

4. VALVE OPERATION

- To assure maximum valve performance, only use a valve that is suitable for the rated pressure/temperature and corrosive environment.
- For your safety and normal operation, please read the following valve operation procedures: Never operate the valve without authorization and a full understanding of the safe operation procedures, inspections and proper handling instructions.
- For sizing, C_v value and cracking pressure for swing check valve Table 2 & Table 3:

Table 2 - Cv value for swing check valve

Size	Units (gal/min)/(lbf/in ²) ^{0.5}					
	150LB	300LB	600LB	900LB	1500LB	2500LB
2	123.9	123.9	123.9	105.0	105.0	68.1
3	281.8	281.8	281.8	259.6	239.4	159.6
4	524.1	524.1	524.1	482.7	425.5	267.1
6	1234.6	1234.6	1234.6	1140.7	988.2	659.3
8	2281.5	2281.5	2213.5	2021.0	1751.1	1180.7
10	3573.7	3573.7	3404.3	3137.6	2729.9	
12	5340.4	5340.4	5104.7	4569.4	3975.9	
14	6511.0	6511.0	6142.9	5565.3	4794.4	
16	8624.9	8624.9	8068.6	7268.9	6267.6	
18	11472.8	11155.6	9575.4			
20	14304.0	13964.2	12884.7			
24	20866.1	20419.8	18682.8			
30	33735.6				-	

Table 3 - Cracking pressure for swing check valve

Size	Units (Psi)					
	150LB	300LB	600LB	900LB	1500LB	2500LB
2	0.28	0.29	0.32	0.69	0.74	1.03
3	0.33	0.36	0.41	0.46	0.63	1.24
4	0.26	0.28	0.25	0.40	0.65	1.03
6	0.18	0.17	0.30	0.52	0.54	1.24
8	0.22	0.22	0.33	0.57	0.70	1.53
10	0.19	0.19	0.31	0.60	0.84	
12	0.21	0.21	0.41	0.58	0.89	
14	0.30	0.31	0.48	0.56	1.42	
16	0.25	0.25	0.47	0.72	1.4	
18	0.24	0.31	0.52	0.80		
20	0.27	0.33	0.52			
24	0.26	0.42	0.55			

5. VALVE MAINTENANCE

Valves should be inspected regularly during operation and any findings should receive immediate attention in order to avoid any further damage to the valve or the system. Regular inspection and maintenance should be scheduled at a minimum of twice per year, or more often if required.

5.1 Valve surfaces are areas that will easily accumulate dust, corrosion, oil and debris, thus resulting in excessive wear and damage. Therefore regular inspection and cleaning of these components is necessary.

5.2 Regular maintenance and inspection of the valve is required to assure smooth operation. Hinge and swing pins should be inspected and lubricated frequently to ensure proper operation. Inspection should confirm that the valve is sealing properly. For water & oil service, regular maintenance should be scheduled every three months. For more corrosive mediums, inspection and maintenance should be completed once a month.

5.3 Valves that are not operated frequently; remaining in the open or closed positions for long periods of time should be partially operated on a monthly basis to expel lubricant throughout.

5.4 During maintenance or servicing of the valve, all replacement parts must be the same as the original specification (parts dimensions and materials). End user may also purchase the spare parts such as packing, gaskets, bolts/nuts etc. when ordering the valve. With the new gasket or bolt/nuts installed, the valve must pass the applicable pressure testing prior to installation and service.

5.5 If the seating surfaces of the disc or the seats are scratched or show slight pitting of less than 0.005" (0.1 mm): these can be removed by lapping. If defects are deeper than 0.005", proper machining practices of grinding and machining by qualified machinist should be implemented. To assure the sealing capability, the valve must pass all required applicable pressure tests before returning to service. If all pressure containing parts are in need of repair, consideration of replacing the valve should be made.

5.6 At NO time shall any weld repair be conducted on the valve while in service. Never strike the valve with a hammer or other impact device. Ensure that no excess weight is placed on the valve that was not part of the original manufacturer design.



WARNING: ANY MAINTENANCE OR REPAIR MUST NOT OCCUR UNTIL THE VALVE BODY PRESSURE IS COMPLETELY RELEASED. NO REPAIR WORK SHALL BE CONDUCTED WHILE THE VALVE IS UNDER PRESSURE.



6. DETAILED DISASSEMBLY AND ASSEMBLY

6.1 BOLTED BONNET CHECK VALVE DISASSEMBLY

- 6.1.1 Loosen and remove the bonnet/body flange bolts and nuts.
- 6.1.2 Use the proper design and sized hoist or crane to remove the bonnet.
- 6.1.3 Remove the disc/swing arm/hinge assembly;
- 6.1.4 Remove the bonnet gasket from the body.
- 6.1.5 If necessary, remove the pin from the swing arm/hinge
- 6.1.6 If necessary, remove the spot weld on the disc nut, then remove the disc nut, pin, swing arm and disc in sequence.

6.2 BOLTED BONNET CHECK VALVE ASSEMBLY

- 6.2.1 When re-assembling the valve, inspect and ensure that all components are thoroughly clean before installing into the valve body. All rust and dirt should be removed with a wire brush or emery cloth. Oil solids and grease adhered to the valve internals should be removed with approved solvents.
- 6.2.2 Apply a thin layer of light oil on the sealing surface to avoid any scratches that may occur during the assembly process.
- 6.2.3 Install the hinge in to the disc, install the disc nut onto the disc hinge assembly and tighten.
- 6.2.4 Install the hinge pin into the swing arm and hinge.
- 6.2.5 Install the disc/swing arm/hinge assembly into the body, ensure that bolt holes on the swing arm are aligned with valve body boss bolt holes, install the hex nuts and washers , tighten them and spot weld.
- 6.2.6 Install new body gasket and bonnet in to the body. Install the bolts/nuts.
- 6.2.7 Ensure that all studs and nuts are clean and free of rust, corrosion, burrs and previous lubricants. DHV recommends installing new bolting when assembling body and bonnet connections. DHV recommends coating the stud threads and surface under the nut with the molybdenum disulfide. All tightening of the bolting should be by hand; followed by the appropriate tightening sequences outlined in Table 1 Bolt Tightening Torque Chart & Figure 2 Bolt Tightening Sequence. It is important to follow proper torque procedures. Each bolt should be torqued in steps of approximately 20% of final torque. Recheck all bolting once completed.
- 6.2.8 Over torque can cause deformation of the body/bonnet flange causing leakage. Failure to properly follow the tightening sequence will result in the gasket not being compressed evenly, resulting in gasket leakage.
- 6.2.9 **WARNING:** Never use impact devices to tighten the bolting on the body/bonnet connections. Use



suitable designed mechanical devices such as hand torque wrenches for tightening and refer to Table 1. Torque wrenches and standard wrenches may be used in combination when performing tightening sequences.

6.2.10 To assure the valve is sealing properly, perform the required pressure testing per recognized and applicable design standards.

Table 4

When Torque Wrenches are Not Available or Suitable, The Use of Standard Wrenches and Guidelines Will Apply to Avoid Over Torque or Damage to the Valve.	
BOLT SIZE	LENGTH OF WRENCH (inches)
3/8"	5"
1/2"	6"
9/16"	9"
5/8"	12"
3/4"	18"
7/8"	24"
1"	30"
1-1/8"	36"
1-1/4"	42"

7. TROUBLESHOOTING

PROBLEM	PROBABLE CAUSE	REMEDY
Leakage at sealing surface	Dirt on the sealing surface	Clean the sealing surface
	Sealing surface damaged	Repair the sealing surface
Cannot operate normally	Dirt debris may be trapped between Hinge/Swing Arm/Hinge Pin	Remove dirt or debris
Bonnet gasket leakage	Loosen flange bolt/nut	Re-torque the flange bolt/nut
	Bonnet gasket failed	Replace with new gasket
Valve body and bonnet both damaged and valve leaks	Corrosion over time. Wall thickness may be below minimum required	Regularly check the wall thickness, replace the valve ahead of the time.
Disc will not operate normally	Hinge Pin maybe deformed and jammed	Replace valve Hinge Pin



8. WARRANTY AND SERVICE

8.1 VALVE WARRANTY PERIOD

8.1.1 Valve warranty period is 12 months from the date shipped from the factory.

8.1.2 In the event the end user encounters an issue of quality, please notify DHV immediately. DHV reserves the right to investigate and settle all issues of quality concerns directly with the end user. Refer to DHV's standard warranty policies for questions or concerns regarding warranty concerns.

8.1.3 Addressing a valve quality issue within the warranty period:

DHV reserves the right to review and respond to all requests for warranty repair or replacement, prior to making any replacement or repairs by the end user.

8.1.4 DHV will not be held responsible for any damage due to natural disaster, such as earthquake, hurricane etc. during valve shipment.

8.1.5 DHV must to be consulted for any warranty issue before being held responsible for any repairs or valve replacement.

8.2 SERVICE

8.2.1 If required by the contract, DHV may provide and perform field installation and start up testing.

8.2.2 Upon end user request, DHV can provide services in monitoring the valve quality and history for Long Term Ownership. Additionally, DHV can provide all the necessary training of repair services to the valve, as well as training on safe valve operations.



DHV Industries, Inc.

3451 Pegasus Drive

Bakersfield, CA 93308 USA

Call Toll Free: (833) DHV-USA1

Phone: (661) 392-8948

Fax: (661) 392-8947

E-mail: sales@dhvindustries.com

Website: www.dhvindustries.com

DHV Valve Company, Inc.

10401 South Sam Houston Pkwy West,

Houston, TX 77071 USA

Call Toll Free: (844) 828-2169

TEL: (346)304-2968

Fax: (346)304-2971

E-mail: sales@dhvvalve.com

Website: www.dhvvalve.com

DHV is committed to providing you with the necessary information to support our products. Our global network of authorized service centers, technical support personnel and warranty support personnel are ready to serve your needs for support on applications, products, service and warranty. Contact our USA Bakersfield headquarters for immediate assistance to your support needs.