

INSTALLATION, OPERATION AND MAINTENANCE MANUAL

API 623 CAST STEEL GLOBE VALVE

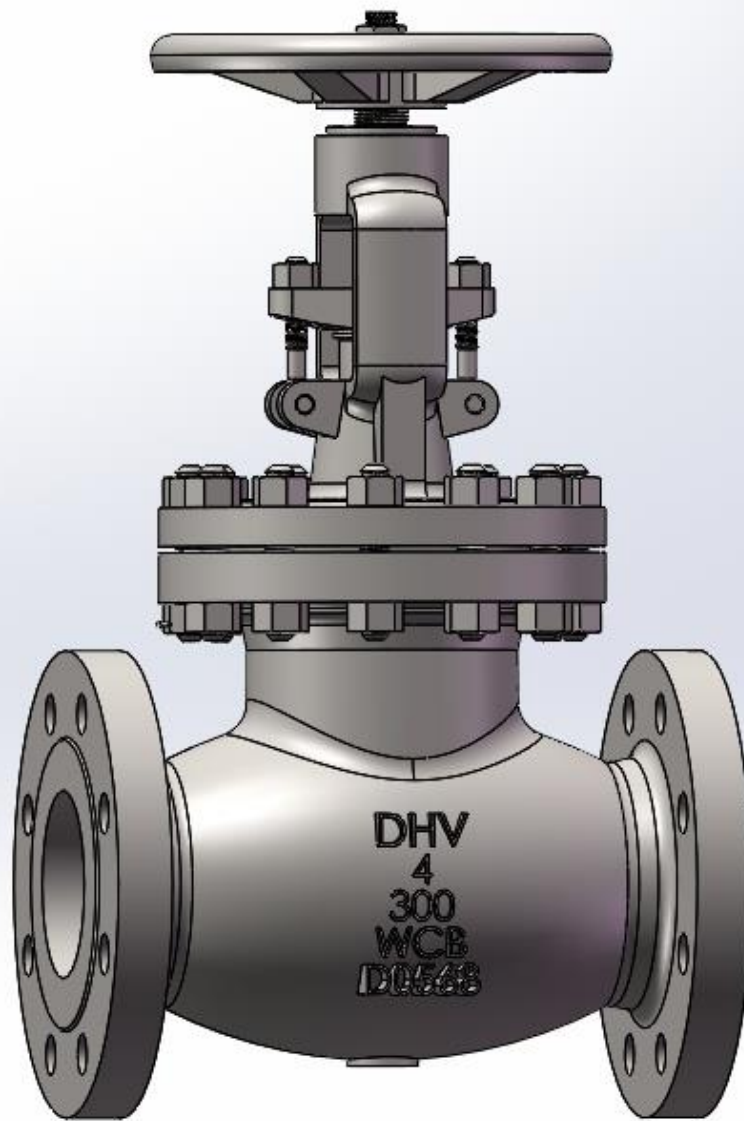

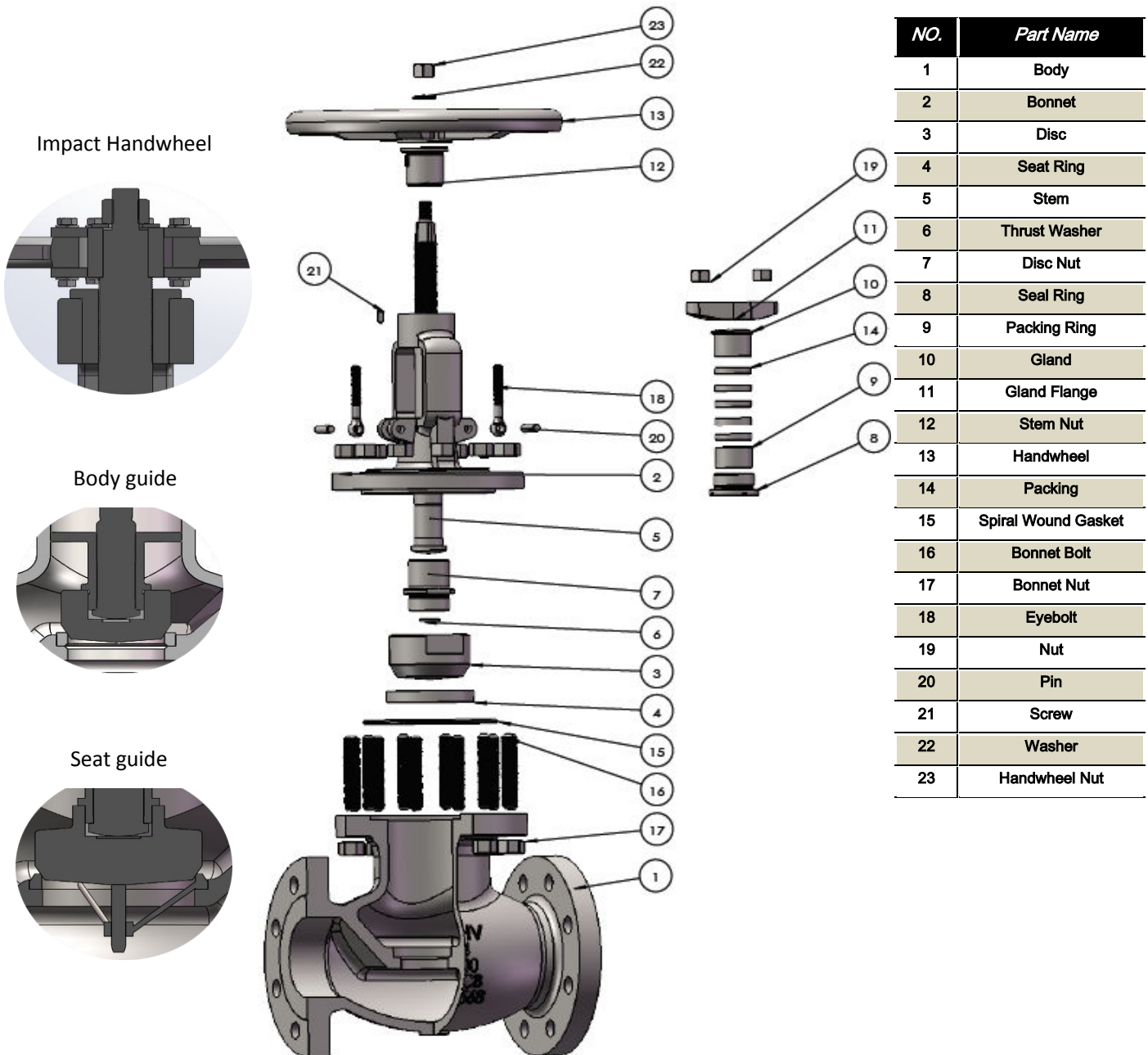

TABLE OF CONTENTS

TYPICAL CONFIGURATION	3
FOREWORD	4
1. ENDUSER INSTRUCTION	4
2. VALVE TRANSPORTATION AND STORAGE	5
2.1 TRANSPORTATION	5
2.2 STORAGE	5
3. VALVE INSTALLATION	6
3.1 INSPECTION BEFORE INSTALLATION	6
3.2 INSTALLATION	7
4. VALVE OPERATION	10
5. VALVE MAINTENANCE	11
6.DETAILED DISASSEMBLY AND ASSEMBLY	Error!
Bookmark not defined.	
6.1 BOLTED BONNET GLOBE VALVE DISASSEMBLY	12
6.2 BOLTED BONNET GLOBE VALVE ASSEMBLY	13
6.3. PACKING INSTALLATION SEQUENCE	14
7. TROUBLESHOOTING	17
8. WARRANTY AND SERVICE	18
8.1 VALVE WARRANTY PERIOD	18
8.2 SERVICE	18
APPENDIX I – INSTALLATION REQUIREMENTS	19

TYPICAL CONFIGURATION

API 623 CAST STEEL GLOBE VALVE



NO.	Part Name
1	Body
2	Bonnet
3	Disc
4	Seat Ring
5	Stem
6	Thrust Washer
7	Disc Nut
8	Seal Ring
9	Packing Ring
10	Gland
11	Gland Flange
12	Stem Nut
13	Handwheel
14	Packing
15	Spiral Wound Gasket
16	Bonnet Bolt
17	Bonnet Nut
18	Eyebolt
19	Nut
20	Pin
21	Screw
22	Washer
23	Handwheel Nut



FOREWORD

Personal Safety and Long Term Ownership of your DHV API 623 Globe Valve is the most important matter in reviewing our Installation, Operation & Maintenance Manual. This manual will provide all the necessary safety guidelines for our valve including information for the valve transportation, storage, installation, operation and maintenance. Please read carefully before installing or servicing the valve.

DHV provides general guidelines in this manual, and cannot provide specific data and warnings for all possible applications. The purchaser/end user must therefore assume responsibility for proper valve selection, sizing, installation, operation, and maintenance of DHV valve products. The purchaser/end user should read and understand this document and any instructions provided with the product, and conduct training with its employees and contractors to ensure they are aware of the proper and safe use of DHV valve products in connection with the specific application.

1. ENDUSER INSTRUCTION

Personnel safety is always the most important factor in the transportation, storage, installation, operation and maintenance of any valve. DHV valves are designed to meet the customer's order requirements and specifications. DHV disclaims all responsibility for problems that may be caused by applications other than the specified use. Valve service pressure/temperature information is detailed on the valve name plate. When selecting a valve, always consider the application, service and temperature for the intended service. Select the applicable valve material for anti-corrosion and anti-abrasive service. For safety of personnel and plant/environment: Prior to conducting any service on the valve, ensure the valve is not under pressure, properly vented, and drained. For all electric, hydraulic or pneumatic actuated valves, all power connections to the valve/actuator must be turned off before performing any maintenance and service. When performing any operation, maintenance or service, personal protective equipment should be used, such as protective clothing, oxygen masks, safety glasses, work gloves, etc. DHV will not be responsible for any loss or expense resulting from the failure of equipment, damage to any property, or death or injury to any person resulting in whole or in part from repairs or modifications performed by other than authorized DHV personnel. Such unauthorized repairs shall also serve to terminate any contractual or other warranty, if any, on the equipment and may result in the equipment no longer meeting applicable requirements.



2. VALVE TRANSPORTATION AND STORAGE

2.1 TRANSPORTATION

1. Valves should remain in the closed position to prevent damage to the seating surface during shipping and handling. Each valve should be securely packaged either on a pallet or in a crate to avoid any damage during shipping.
2. Use the proper hoisting equipment to transport the valve, especially when lifting or lowering the valve. Special attention to personnel safety and the care of the valve should be made when transporting the valve. Avoid impacting or striking the valve during transportation. Lay the valve on a clean flat surface; avoid laying the valve on the flange face. Ensure there is adequate clearance around the valve for proper operation and maintenance.
3. When lifting the valve, use the valve lifting lugs; if the valve does not come with lifting lugs, use an appropriate sized sling through the valve yoke to lift the valve.

 **WARNING: NEVER USE THE HANDWHEEL OR VALVE STEM TO LIFT THE VALVE.**

4. During transportation, ensure the valve's paint, name plate and flange sealing surfaces are fully protected. Do not drag the valve across the floor, or place the valve flange sealing face on the floor.
5. For those valves not required to be immediately installed, do not open the end flange protective covers. Ensure the valves are stored in a safe, clean environment and are protected from rain and dust.

2.2 STORAGE

1. Valves should be stored in the closed position. Valve ports and flange serration surfaces should be kept sealed with protective flange covers.
2. Valves should be stored in a dust free, low humidity and well-ventilated room, not in direct contact to the floor. If possible, the valves shall be kept in the original packing box. If the valves must be stored outdoors, keep them in the original crate or shipping container. Ensure the valve's packaging is stored on raised blocking to avoid moisture damage. Protective covering should be used for protection against dust and rain.
3. Valves should never be stacked on top of each other, to avoid any valve distortion which may affect valve performance and cause personnel injury.



4. Valves that have been stored for an extended time should be cleaned and inspected prior to installation. Inspect the sealing surface to ensure it is clean and free of any debris or damage.
5. Do not expose the valve to any corrosive environment as this may cause damage to the valve stem threads.

3. VALVE INSTALLATION

- Review all documentation to fully understand the valve and related information that will provide safe installation and a long service life for your valve.
- Valve information can be found on the valve body, and the name plate. Fig 1 is a typical nameplate.
- Valve ends should have a protective cover to protect the valve bore from any foreign particles and dust which will damage the disc and seat sealing surfaces.

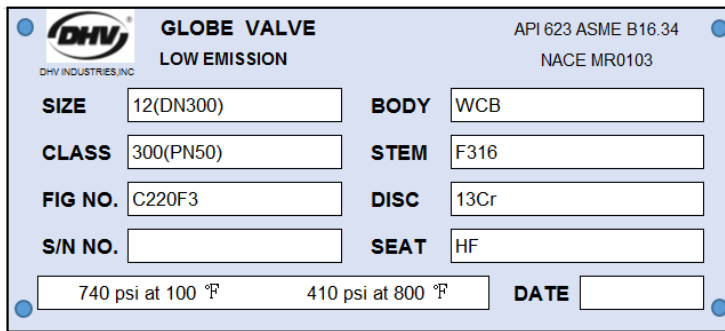

Figure 1 Typical Valve Nameplate

SIZE	Nominal Valve Size
CLASS	Pressure Class
FIG NO.	Figure NO. See DHV's Catalog
S/N NO.	Valve Series Number
BODY	Body Material
STEM	Stem Material
DISC	Disc Surface Material
SEAT	Seat Surface Material
psi at °F	Pressure-temperature Rating
DATE	Manufacture Date

Nameplate Information

3.1 INSPECTION BEFORE INSTALLATION

3.1.1 Before installation, check the valve name plate and valve body information to ensure the valve is suitable for the intended service.

3.1.2 Before installation, remove the flange cover and the protective film on the flange sealing face, inspect the bore and the flange sealing surface, remove any dirt with a clean soft cloth, use an anti-corrosive cleaning liquid to clean if necessary, and never use any other chemical products.

3.1.3 Inspect the flange gasket (including ring gasket) sealing surface and ensure it is in acceptable condition for installation.

3.1.4 After cleaning the valve and before installation, open and close the valve one time. Ensure the valve operates smoothly. If abnormal operation is experienced, stop the operation and inspect the valve stem and valve bore for any obstructions that may be preventing normal operation.

3.1.5 After successfully cycling and assuring the proper operation of the valve, return the valve to the closed position until installation is complete. If for any reason the valve must remain in the open position, ensure the valve sealing surfaces are protected.

3.2 INSTALLATION

3.2.1 Position the valve into the pipe or the flange connection; ensure that any stress caused by improper pipe alignment is relieved first. Valves are not intended to be a means of aligning improperly fitted pipe.

3.2.2 Install the valve using qualified piping standards and practices. Valves marked with flow direction must be installed in line with the piping flow.

3.2.3 The recommended orientation for globe valves is upright with the valve in a horizontal line with the handwheel positioned vertically above the valve centerline. The valve may be installed in other orientations; however, any deviation from recommended vertical position may compromise proper valve operation. See Appendix I for details.

FLANGE ENDS:

- Select the proper gasket (including ring gasket) to install, line up the bolt holes between the valve flange and pipeline flange, then install the bolts and nuts and tighten to the accepted piping and bolting standards. The bolt threads should be lubricated first for ease of bolting.
- Use an appropriate sized torque wrench when tightening the bolt/nut, to avoid flange deformation. Please follow Fig 2 and Table 1 for bolting sequence and bolting torque. If the bolting quantity is different from the chart shown, please follow the same principle to get a new sequence to follow.
- For large diameter valves, the valve must be properly and safely supported during installation. After installation is completed, valve supports should be moved to the bottom of the valve flanges.
- After valve installation is complete, recheck and tighten the bolts including the gland bolts as necessary to the values provided in Table1 & Figure 2.
- It is recommended that the tightness of the joint bolt tension and gland bolts be inspected at least yearly. Refer to Table 1 & Figure 2.



WARNING: DURING INSTALLATION, IF VALVE IS NOT IN LINE WITH THE PIPELINE, FLANGE FACES ARE NOT PARALLEL TO EACH OTHER, OR BOLTING TORQUE IS NOT UNIFORM, VALVE LEAKAGE MAY BE EXPERIENCED.



Table 1 Bolting Tightening Torque Chart

Stud Size (Inch)	Measurement: Newton-meters N·m Tolerance: +/- 10% (Conversion: 1 ft·lb= 1.36 N·m 1 N·m = .74 ft·lb)						
	B7M/L7M	B7/L7	B8 (I)/ B8M(I)	B8M (II)	B8 (II)	B8MLCuN	B16
5/16-18UNC	21	27	8	25	26	9	28
3/8-16UNC	36	47	13	43	45	16	48
1/2-13UNC	85	111	32	101	107	37	112
9/16-12UNC	121	158	45	144	152	53	160
5/8-11UNC	165	217	62	197	208	72	218
3/4-10UNC	289	378	108	344	362	126	380
7/8-9UNC	459	601	171	459	-	200	605
1-8UNC	683	894	255	683	-	298	901
1-1/8-8UN	992	1298	370	811	-	433	1308
1-1/4-8UN	1381	1807	515	1130	-	602	1820
1-3/8-8UN	1860	2435	693	1167	-	812	2452
1-1/2-8UN	2438	3192	909	1530	-	1064	3214
1-5/8-8UN	3126	4092	1165	-	-	1364	4120
1-3/4-8UN	3931	5146	1465	-	-	1715	5182
1-7/8-8UN	4863	6367	1813	-	-	2122	6411
2-8UN	5933	7767	2211	-	-	2589	7820
2-1/4-8UN	8519	11152	3175	-	-	3717	11229
2-1/2-8UN	11764	15400	4385	-	-	5133	15507
2-3/4-8UN	15742	18747	5867	-	-	6869	18747
3-8UN	20528	24447	7651	-	-	8958	24447

Table 1 Bolting Tightening Torque Chart (cont.)

Stud Size (Metric)	Measurement: Newton-meters N·m Tolerance: +/- 10%						
	(Conversion: 1 ft·lb= 1.36 N·m 1 N·m = .74 ft·lb)						
	B7M/L7M	B7/L7	B8 (I)/ B8M(I)	B8M (II)	B8 (II)	B8MLCuN	B16
M10	43	56	16	51	54	19	56
M12	73	96	27	87	92	32	96
M16	175	230	66	209	221	77	232
M20	338	443	126	338	424	148	446
M24	578	757	215	578	-	252	762
M30	1134	1484	422	928	-	495	1495
M36	1964	2572	732	1232	-	857	2589
M42	3125	4091	1165	1960	-	1364	4119

Figure 3 Bolt Tightening Sequence

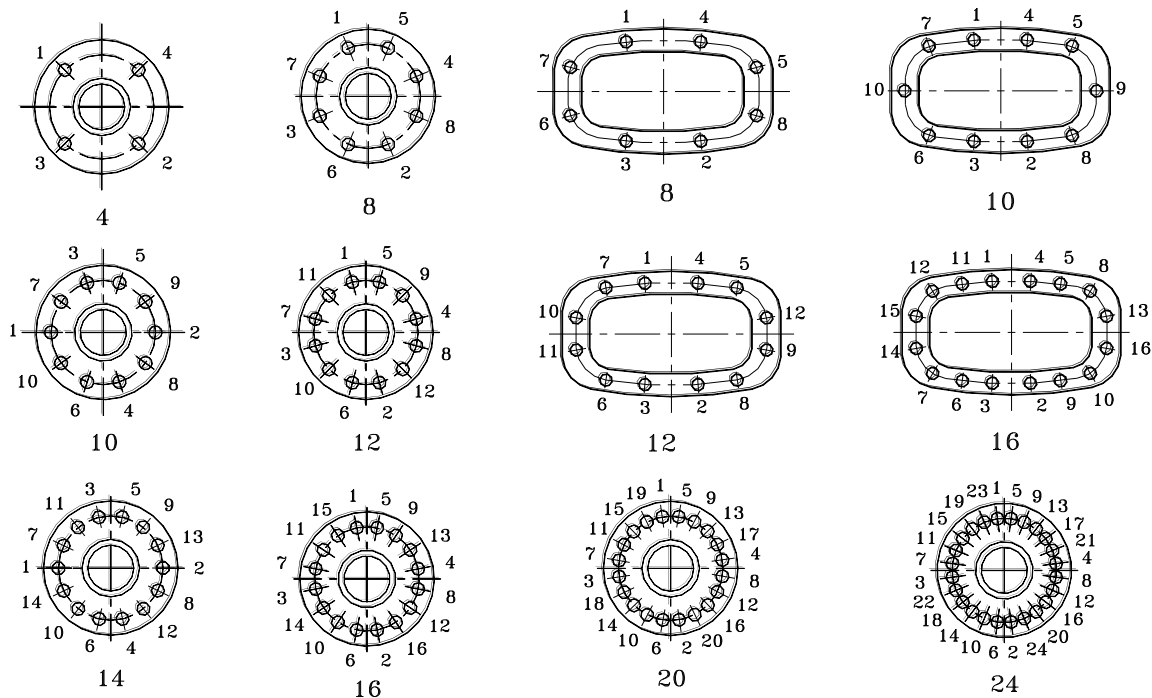



WELD ENDS:

- Weld ends must be kept clean with no burrs, oil, dirt or foreign objects.
- The valve end and pipe end must be in proper alignment for effective welding.
- Follow the approved WPS to perform the welding. During welding, insure the temperature near the seat area does not overheat which will cause sealing area distortion. Protect the valve bore area to prevent welding slag and foreign matter from entering the valve.
- After welding, use approved and proper Non-Destructive Testing (NDT) method to check the welds; clean the weld thoroughly, and then perform local heat treatment if required.
- When installation is complete, and prior to system testing and start-up, clean the valve by flushing the line of debris and other materials that may have accumulated inside the valve and in the valve seating area and surfaces during construction. When flushing the valve, open the valve fully, flush for a determined time based on line size. Close the valve and allow fluid to fill the line, while opening and closing the valve while flushing. Fully close the valve, if seat leakage is noted after flushing, repeat flushing procedure. If leakage from the seat is still evident, the seating surface maybe damaged and need repair.

4. VALVE OPERATION

- To assure maximum valve performance, only use a valve that is suitable for the rated pressure/temperature and corrosive environment.
- For your safety and normal operation, please read the following valve operation procedures:
 - 4.1** The valve must be kept either in the fully open or fully closed position. Never throttle or leave the valve at the half-open position as erosion of the disc and seating surface may occur and stem damage will result.
 - 4.2** Rotating the valve hand wheel clockwise will close the valve; counter-clockwise operation will open the valve, this is also applicable to gear or motor actuated operation. Closing the valve requires the specified stem torque to assure the closure of the valve at the rated pressure.
 - 4.3 CAUTION:** For personal safety, always use an appropriate sized valve wrench to open and close the valves (Recommendation: A valve wrench no larger than twice the diameter of the handwheel should be used when opening or closing a valve). Never use an oversized torque wrench (with higher torque output) to operate the valve, as over torquing may result in permanent distortion to the internal valve components, resulting in the valve malfunctioning. The use of pneumatic impact wrenches for the quick opening or closing of the valve is not recommended; binding or stem damage may occur.
 - 4.4** Never operate the valve without authorization and a full understanding of the safe operation procedures, inspections and proper handling instructions.
 - 4.5** When a valve is in the fully open position, rotate the handwheel one quarter turn from the fully



open position. This action will ensure that packing tightness is verifiable.

4.6 Back seating a valve is means of stopping or reducing packing leakage until the packing can be replaced. Valve packing should only be replaced when the valve is NOT under pressure. It is not recommended to repack a valve under pressure. To backseat the valve, rotate the hand wheel to the fully open position; do not over torque as this will cause thermal binding.

5. VALVE MAINTENANCE

Valves should be inspected regularly during operation and any findings should receive immediate attention in order to avoid any further damage to the valve or the system. Regular inspection and maintenance should be scheduled at a minimum of twice per year, or more often if required.

5.1 Valve surfaces and other moving parts such as the stem, handwheel or gear operators, are areas that will easily accumulate dust, corrosion, oil and debris, thus resulting in excessive wear and damage. Therefore regular inspection and cleaning of these components is necessary. Stem threads should be lubricated regularly with a lubricant containing copper, molybdenum disulfide lubricant or a motor oil MP equivalent up to 650°F.

5.2 Regular maintenance of the valve is required to assure smooth operation. Stem threads should be inspected and lubricated frequently to ensure ease of operation. Lubrication of the stem should be conducted every six months or more often as needed, based on the environment the valve is installed. Inspection should confirm that the valve is sealing properly. Stem packing should be inspected at least every six months to ensure zero leakage from the packing chamber. For water & oil service, regular maintenance should be scheduled every 3 months. For more corrosive mediums, inspection and maintenance should be completed once a month.

5.3 Valves that are not operated frequently; remaining in the open or closed positions for long periods of time should be partially operated on a monthly basis to expel lubricant throughout the stem nut, bearings or gears. Excessive effort to open or close the valve may indicate the valve stem needs to be lubricated, or the valve packing compression is too tight (Verify the eye bolt torque in Table 3), or if debris and particle matter on the threads are preventing the operation of the stem. Damaged components should be considered when the valve will not operate after all efforts of adjustments and lubrication has been completed.

5.4 During maintenance or servicing of the valve, all replacement parts must be the same as the original specification (parts dimensions and materials). End user may also purchase the spare parts such as packing, gaskets, bolts/nuts etc. when ordering the valve. With the new packing, gasket or bolt/nuts installed, the valve must pass the applicable pressure testing prior to installation and service.

5.5 If the seating surfaces of the disc or the seats are scratched or show slight pitting of less than 0.005" (0.1 mm): these can be removed by lapping. If defects are deeper than 0.005", proper machining practices of grinding and machining by qualified machinist should be implemented. To assure the sealing



capability, the valve must pass all required applicable pressure tests before returning to service. If all pressure containing parts are in need of repair, consider replacing the entire valve.

5.6 At NO time shall any weld repair be conducted on the valve while in service. Never strike the valve with a hammer or other impact device. Ensure that no excess weight is placed on the valve that was not part of the original manufacturer design.



WARNING: ANY MAINTENANCE OR REPAIR MUST NOT OCCUR UNTIL THE VALVE BODY PRESSURE IS COMPLETELY RELEASED. NO REPAIR WORK SHALL BE CONDUCTED WHILE THE VALVE IS UNDER PRESSURE.

6. DETAILED DISASSEMBLY AND ASSEMBLY

6.1 BOLTED BONNET GLOBE VALVE DISASSEMBLY

- 6.1.1 Loosen and remove the eye bolt nuts and bonnet/body flange bolts and nuts.
- 6.1.2 Use the proper design and sized hoist or crane to remove the bonnet assembly;
- 6.1.3 Turn the handwheel clockwise to remove the stem assembly, carefully holding the stem; If necessary, remove the spot weld between the disc and disc nut, and then remove the disc from the stem.
- 6.1.5 Remove packing flange and packing gland, use a packing hook or similar tool to remove the packing from the packing bore, take care that you do not damage the packing bore sealing surface finish.
- 6.1.6 Remove the bonnet gasket from the body.
- 6.1.7 When removing the hand wheel; if necessary, remove any spot welding first, then remove hand wheel, gland, and bearing and stem nut in sequence.
- 6.1.8 For valves fitted with an actuator or gear operator: follow the order in removing the top flange bolts, nuts, packing gland bolts, nuts, spring, disc. Remove the gear box or actuator from the top, and carefully observe the outside configuration of the gear box or the actuator.
- 6.1.9 If necessary, loosen the yoke/bonnet bolt/nut, separate the yoke and the bonnet (some valve configurations, yoke and bonnet is one part).
- 6.1.10 Unless it has been damaged, we do not recommend removal of the back seat.



6.2 BOLTED BONNET GLOBE VALVE ASSEMBLY

- 6.2.1 Apply a thin layer of light oil on the sealing surface to avoid any scratches that may occur during the assembly process.
- 6.2.2 When re-assembling the valve, ensure that all orientation marks stamped or marked on the valve body, bonnet and other components are installed in the same orientation within the valve body and bonnet. Inspect and ensure that all components are thoroughly clean before installing into the valve body or bonnet. All rust and dirt should be removed with a wire brush or emery cloth. Oil solids and grease adhered to the valve stem and yolk should be removed with approved solvents. All threaded components should be well lubricated, paying special attention to the valve stem and yolk nut threads. DHV recommended lubricants are referenced in 5.2.
- 6.2.3 Install the stem to the bonnet, install the disc to the stem T-Head, install the disc nut into the disc (spot welding), then install the bonnet assembly into the body.
- 6.2.4 Install new bonnet gasket, stem packing, and then packing gland and gland flange.
Note: For packing installation see section 6.3.
- 6.2.5 Ensure that all studs and nuts are clean and free of rust, corrosion, burrs and previous lubricants. DHV recommends installing new bolting when assembling body and bonnet connections. DHV recommends coating the stud threads and surface under the nut with molybdenum disulfide. All tightening of the bolting should be by hand; followed by the appropriate tightening sequences outlined in Table 1 Bolt Tightening Torque Chart & Figure 2 Bolt Tightening Sequence. It is important to follow proper torque procedures. Each bolt should be torqued in steps of approximately 20% of final torque. Recheck all bolting once completed.
- 6.2.6 Over torque can cause deformation of the body/bonnet flange causing leakage. Failure to properly follow the tightening sequence will result in the gasket not being compressed evenly, resulting in gasket leakage.
- 6.2.7 **WARNING:** Never use impact devices to tighten the bolting on the body/bonnet connections. Use suitable designed mechanical devices such as hand torque wrenches for tightening and refer to Table 1. Torque wrenches and standard wrenches may be used in combination when performing tightening sequences.
- 6.2.8 To assure the valve is sealing properly, perform the required pressure testing per recognized and applicable design standards.

Table 2

When Torque Wrenches are Not Available or Suitable, The Use of Standard Wrenches and Guidelines Will Apply to Avoid Over Torque or Damage to the Valve.	
BOLT SIZE	LENGTH OF WRENCH (inches)
3/8"	5"
1/2"	6"
9/16"	9"
5/8"	12"
3/4"	18"
7/8"	24"
1"	30"
1-1/8"	36"
1-1/4"	42"

6.3. PACKING INSTALLATION SEQUENCE



WARNING: NEVER REPLACE PACKING WHILE THE VALVE IS UNDER PRESSURE

When replacing the stem packing, please follow the sequences below:

6.3.1 Relieve valve body internal pressure, loosen the eye bolts, and remove the gland flange and packing gland (see Figure 3). Lift the flange and gland as high as possible and secure for easy access to the valve packing.

6.3.2 Remove all old packing using a packing hook or other proper tooling; ensure that you do not damage the stem or the packing chamber. Scratches to the stem and the packing chamber no deeper than 0.010" (0.25 mm) can be removed by polishing the surface with a buffing wheel. The surface finish of the packing chamber and the stem should be 16 RMS or better. Clean the packing chamber area thoroughly of all old packing and debris.

- Measure the stem diameter, packing chamber bore and the packing chamber depth. To assure the correct packing size is installed, measure the diameter of the stem, if possible inside the packing chamber bore area, and then measure the diameter of the packing chamber bore. Subtract the ID measurement from the OD measurement, and divide the difference by two. This is the required cross-sectional size of the packing.

6.3.3 When using spool packing, always cut the packing into individual rings. Never wrap the packing into a coil and insert into the packing chamber. Always cut the packing into individual rings. Using a round bar

or wooden dowel that is the same diameter as the valve stem, hold the packing tightly on the bar or dowel, avoid stretching the packing. Using a sharp knife, cut the ring and insert it into the packing chamber, assure that it fits the packing space properly. Cut each additional ring in the same manner.

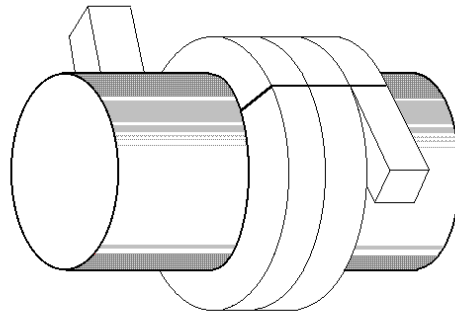

BUTT CUT

6.3.4 IMPORTANT: Install one ring of packing at a time. Insert the packing ring into the packing chamber following the below requirements:

1. Install the first packing ring into the packing chamber, use the packing gland to push down the packing firmly.
2. Apply the same above method to the installing the second graphite ring, however when installing rotate the graphite ring 120° from the first ring. Each additional packing ring should be staggered in the same method of 120°, which will result in the fourth ring installed having its lap back at the starting point. Additional rings should be installed in the same manner. When starting the 3rd graphite ring, it will require compression on the packing gland to the graphite packing to achieve a 20% ~ 25% packing compression.
3. Packing cut position should follow Figure 5. Use the same above method to install rest of the packing, one ring at a time, make sure the packing ring is totally in place before starting next one. During the installation process, keep all packing rings clean without touching any foreign material.
4. After installation of the 5th ring, you must use the packing gland to compress the packing to allow more room to install the 6th ring.
5. After installing the 6th ring, install the packing gland to the packing bore, then install the gland flange, eye bolt and eye bolt nut. Apply the recommended torque to the eye bolt nut per Table 3. Note: as a general rule, ¼" (6 MM) minimum engagement of the gland bushing inside of the packing chamber is required.
6. To assure the valve is functioning properly and the packing is firmly seated after following the required torqueing of the packing bolt/nut, cycle the valve once, for the approximate length of the packing chamber. Cycle the valve fully open and closed, retightening the packing bolt/nut to the required torque, if necessary.

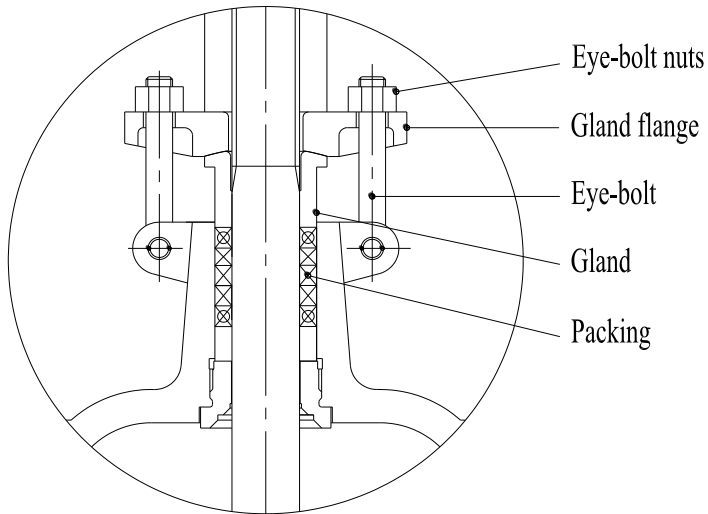

Figure 3 Valve Packing Bore Details

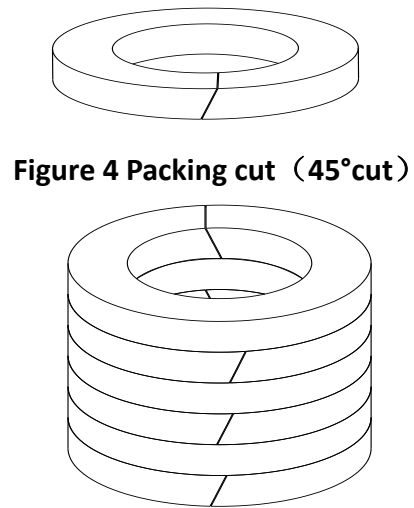

Figure 4 Packing cut (45° cut)

Figure 5 Packing cut position

Table 3 Eye Bolt Tightening Torque Chart

Measurement: Newton-meters N·m Tolerance: +/- 10%												
(Conversion: 1 ft·lb= 1.36 N·m 1 N·m = .74 ft·lb)												
Class	150		300		600		900		1500		2500	
Size	Eyebolt	Torque	Eyebolt	Torque	Eyebolt	Torque	Eyebolt	Torque	Eyebolt	Torque	Eyebolt	Torque
2	1/2	18	1/2	18	1/2	33	5/8	61	5/8	78	1	240
3	1/2	22	1/2	22	5/8	61	3/4	109	7/8	182	1	349
4	1/2	32	1/2	32	5/8	91	7/8	143	1	281	1 1/4	588
6	1/2	34	5/8	62	3/4	166	1	290	1 1/4	536		
8	5/8	47	3/4	114	1-1/8	353	1 1/8	449	1 5/8	1352		
10	5/8	71	7/8	175	1 1/4	554	1 3/8	899	1 5/8	1432		
12	3/4	114	7/8	199	1 1/4	582	1 1/2	1039	1 3/4	2136		
14	5/8	73	1	276	1 1/4	748	1 1/2	1152				
16	7/8	172	1	322	1 3/8	1027						

7. TROUBLESHOOTING

PROBLEM	PROBABLE CAUSE	REMEDY
Packing Chamber Leakage	Eye bolts are loose	Evenly tighten the eyebolts
	Not enough packing / Gland bushing binding	Increase packing ring quantity
	Packing worn / Packing chamber damaged	Replace with new packing
	Stem sealing surface damaged	Replace or repair the stem
Leakage at sealing surface	Dirt or debris on the sealing surface	Clean the sealing surface
	Sealing surface damaged	Repair the sealing surface
Cannot operate normally	Packing compressed too tight	Adjust eye bolt torque
	Stem threads and stem nut threads worn out	Replace stem nut
	Dirt or debris may be trapped between stem/stem nut, or gland flange/gland	Remove dirt or debris
Bonnet gasket leakage	Loosen flange bolt/nut	Re-torque the flange bolt/nut
	Bonnet gasket failed	Replace new gasket
Valve body and bonnet both damaged and valve leaks	Water hammer effect	Careful operation, avoid sudden stopping of the pump or closing the valve too fast
	Corrosion over time. Wall thickness may be below minimum required	Regularly check the wall thickness, replace the valve ahead of the time.
Disc will not operate normally	Stem maybe deformed and jammed	Replace valve stem



8. WARRANTY AND SERVICE

8.1 VALVE WARRANTY PERIOD

8.1.1 Valve warranty period is 12 months from the date shipped from the factory.

8.1.2 In the event the end user encounters an issue of quality, please notify DHV immediately. DHV reserve the right to investigate and settle all issues of quality concerns directly with the end user. Refer to DHV's standard warranty policies for questions or concerns regarding warranty concerns.

8.1.3 Addressing a valve quality issue within the warranty period:

DHV reserves the right to review and respond to all requests for warranty repair or replacement, prior to making any replacement or repairs by the end user.

8.1.4 DHV will not be held responsible for any damage due to natural disaster, such as earthquake, hurricane etc. during valve shipment.

8.1.5 DHV must to be consulted for any warranty issue before being held responsible for any repairs or valve replacement.

8.2 SERVICE

8.2.1 If required by the contract, DHV may provide and perform field installation and start up testing.

8.2.2 Upon end user request, DHV can provide services in monitoring the valve quality and history for Long Term Ownership. Additionally, DHV can provide all the necessary training of repair services to the valve, as well as training on safe valve operations.



APPENDIX I – INSTALLATION REQUIREMENTS

Installation Requirements for DHV brand Globe Valves

Vertical orientation requirement of valves during operation, testing, and installation is prescribed to all globe valves.

Assembly

Includes all hand wheels, gearboxes, or actuators.

- All globe valves operators must be assembled in the upright position vertically above the valve's centerline.
- Gearboxes, actuators and necessary adapters must conform to the valve's ISO pad top works design.
- Adapter plates and gears must be bolted to the valve top works plate using the correct bolt size, torque, and tightening pattern.
- The stem must be protected at all times from unnecessary movement, stress, force or other potential damage while insuring the stem remains centered in the yoke tube during installation

Operation

Globe valves must be oriented in the vertical position any time the valve is operated or cycled.

- Personnel installing the operator must ensure there is no abnormal stem movement or run out during operation.
- All "stops" and or "limits" must be correctly set to prevent damage or unnecessary wear to the valve.

Testing

Applies to all methods of hydro testing and pre-commissioning testing.

- Globe valves must be oriented in the vertical position during any operation and testing processes.
- Procedures must be compliant to API specifications.

Installation

- Globe valves must be installed and operated in the vertical position only.
- Globe valves must always be either fully open, or fully closed once installed and are not designed or intended for throttling applications.

Shipping

Valves need to be fully closed during shipment and actuators need to be braced to support the extra weight at the top end of the valve.

Failure to follow these manufacturer prescribed requirements will void any warranties



DHV Industries, Inc.

3451 Pegasus Drive

Bakersfield, CA 93308 USA

Call Toll Free: (833) DHV-USA1

Phone: (661) 392-8948

Fax: (661) 392-8947

E-mail: sales@dhvindustries.com

Website: www.dhvindustries.com

DHV Valve Company, Inc.

10401 South Sam Houston Pkwy West,

Houston, TX 77071 USA

Call Toll Free: (844) 828-2169

Phone: (346)304-2968

Fax: (346)304-2971

E-mail: sales@dhvvalve.com

Website: www.dhvvalve.com

DHV is committed to providing you with the necessary information to support our products. Our global network of authorized service centers, technical support personnel and warranty support personnel are ready to serve your needs for support on applications, products, service and warranty. Contact our USA Bakersfield headquarters for immediate assistance to your support needs.