

BC SERIES INDUSTRIAL COOLER SYSTEM WITH AXIAL FAN

Max static pressure = 25 bar

Max dynamic pressure = 16 bar

Aluminium air-oil heat exchanger

Suitable for return line and off line

OPTIONAL

Circulation pump - On Request

BC 210 SERIES

12-24V - page 3

Single Phase / Three Phase - page 4



BC 250 SERIES

12-24V - page 5

Single Phase / Three Phase - page 6
with Hydraulic Motor - page 7



BC 250/2 SERIES

12-24V - page 8

Single Phase / Three Phase - page 9
with Hydraulic Motor - page 10



BC 390 SERIES

12-24V - page 11

Single Phase / Three Phase - page 12
with Hydraulic Motor - page 13



BC 390/2 SERIES

12-24V - page 14

Single Phase / Three Phase - page 15
with Hydraulic Motor - page 16



BC 210 SERIES 12-24V



DIMENSIONS AND TECHNICAL CHARACTERISTICS ARE NOT BINDING

Type	Oil flow l/min	Capacity l	Voltage V	Power W	Current A	Air flow m ³ /h	Protection IP	Noise Level dB(A)	Weight Kg
BC 210 12	25-100	1.7	12	70	5.8	600	64	75	6
BC 210 24			24		2.9				

DIMENSIONS

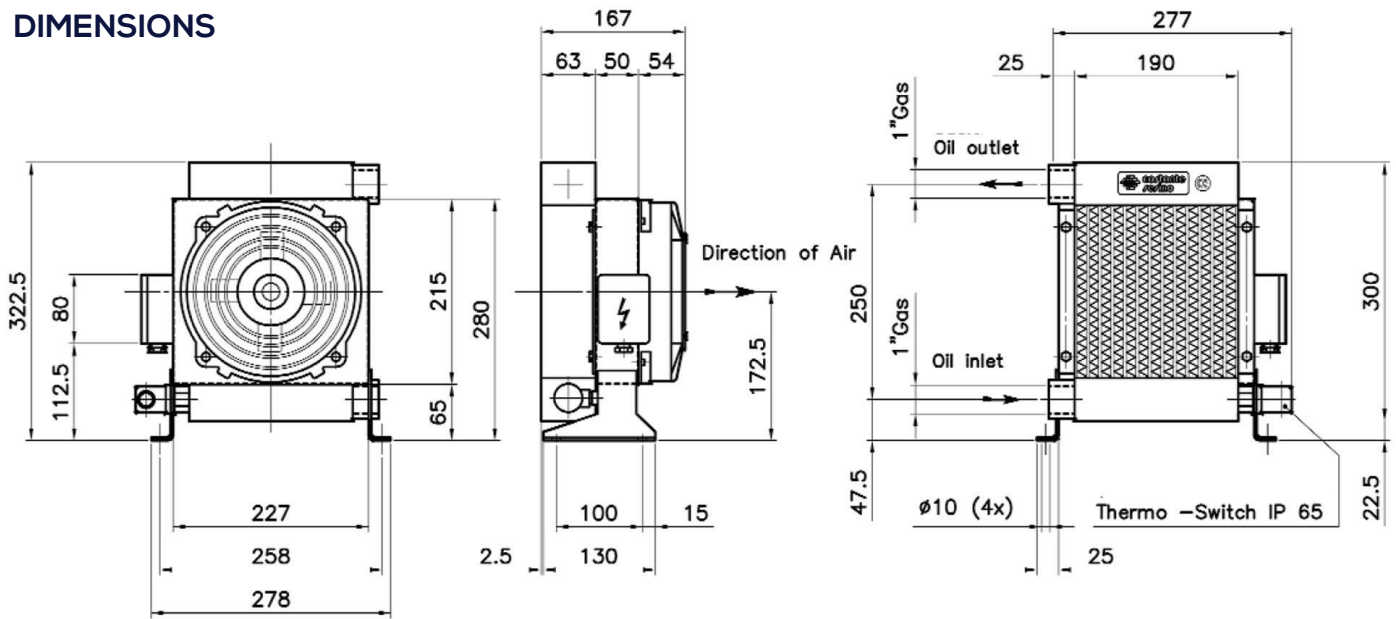

PERFORMANCE DIAGRAM

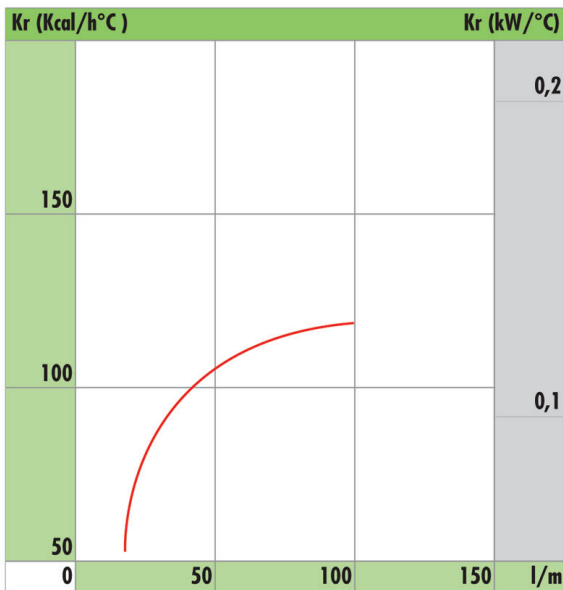

LOSS PRESSURE DIAGRAM - at 30cSt

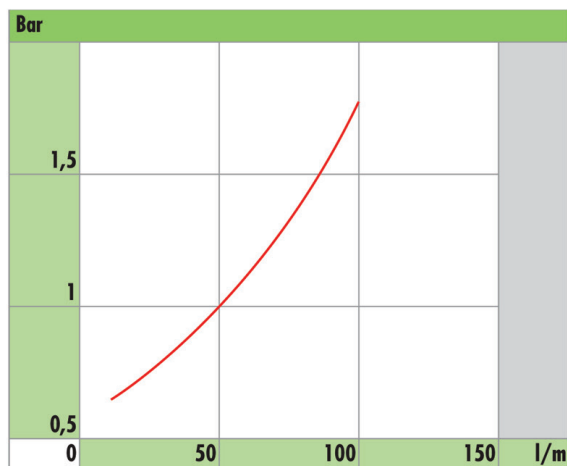

CORRECTION FACTOR

A	22	30	46	68	100	150	220	= cSt
B	0,6	1	1.5	2.3	3.5	5	7	= f

A = Oil viscosity in cSt B = Multiplication factor for pressure loss



BC 210 SERIES SINGLE PHASE / THREE PHASE

DIMENSIONS AND TECHNICAL CHARACTERISTICS ARE NOT BINDING

Type	Oil flow l/min	Capacity l	Voltage V	Frequency Hz	Power W	Current A	Air flow m3/h	Protection IP	Noise Level dB(A)	Weight Kg
BC 210 Single	25-100	1.7	230	50/60	62	0.27	630	44	57	7
BC 210 Three			230-400		68/70	0.17/0.13				

DIMENSIONS

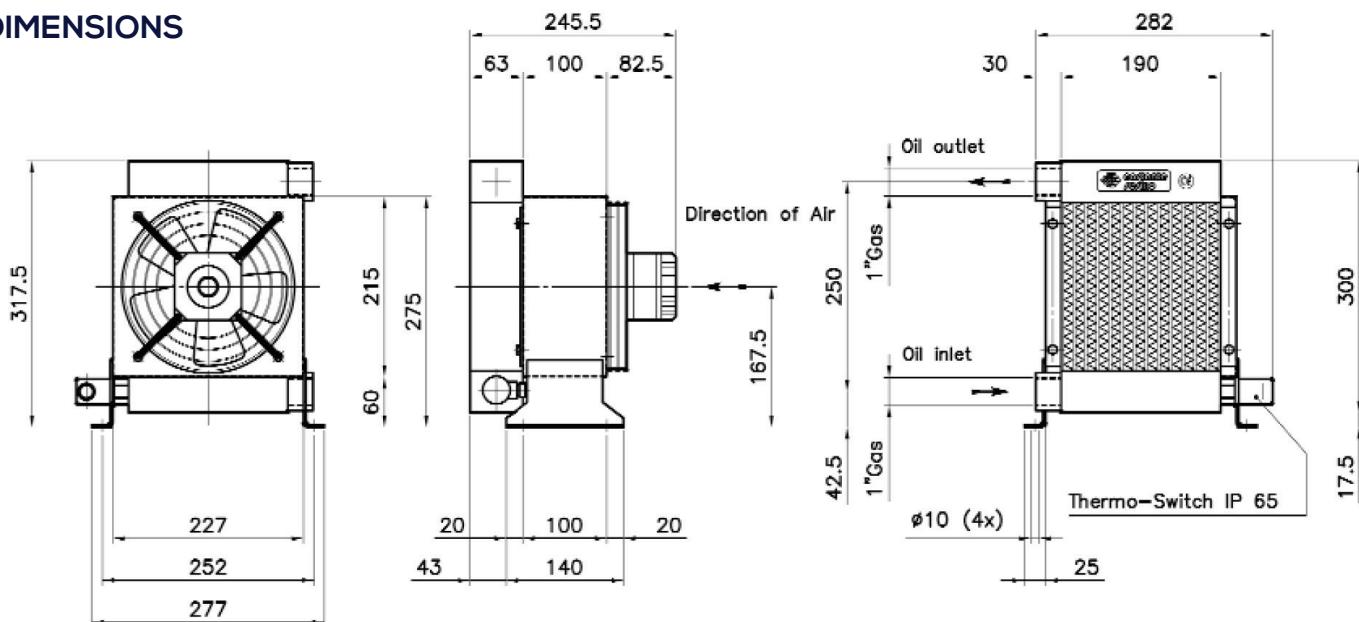

PERFORMANCE DIAGRAM

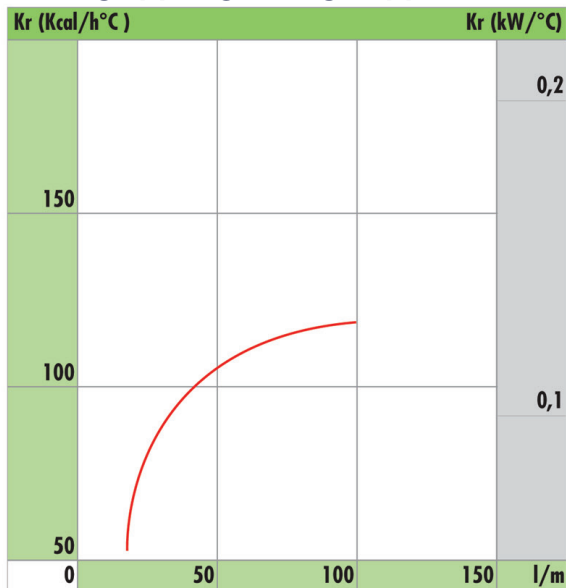

LOSS PRESSURE DIAGRAM - at 30cSt

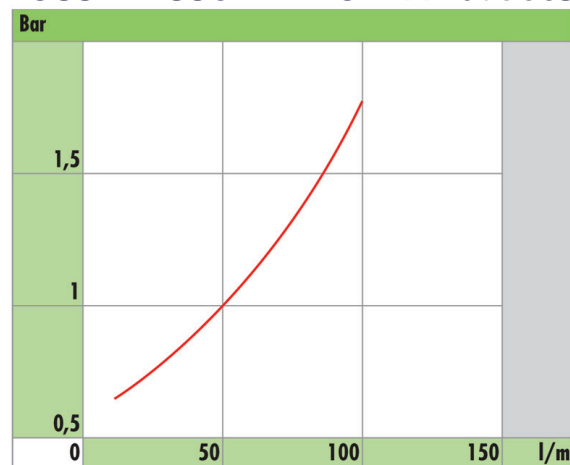

CORRECTION FACTOR

A	22	30	46	68	100	150	220	= cSt
B	0,6	1	1.5	2.3	3.5	5	7	= f

A = Oil viscosity in cSt B = Multiplication factor for pressure loss

BC 250 SERIES 12-24V



AIR BLAST COOLERS

DIMENSIONS AND TECHNICAL CHARACTERISTICS ARE NOT BINDING

Type	Oil flow l/min	Capacity l	Voltage V	Power W	Current A	Air flow m3/h	Protection IP	Noise Level dB(A)	Weight Kg
BC 250 12	25-150	2	12	180	15	1.600	68	79	10
BC 250 24			24		7.5				

DIMENSIONS

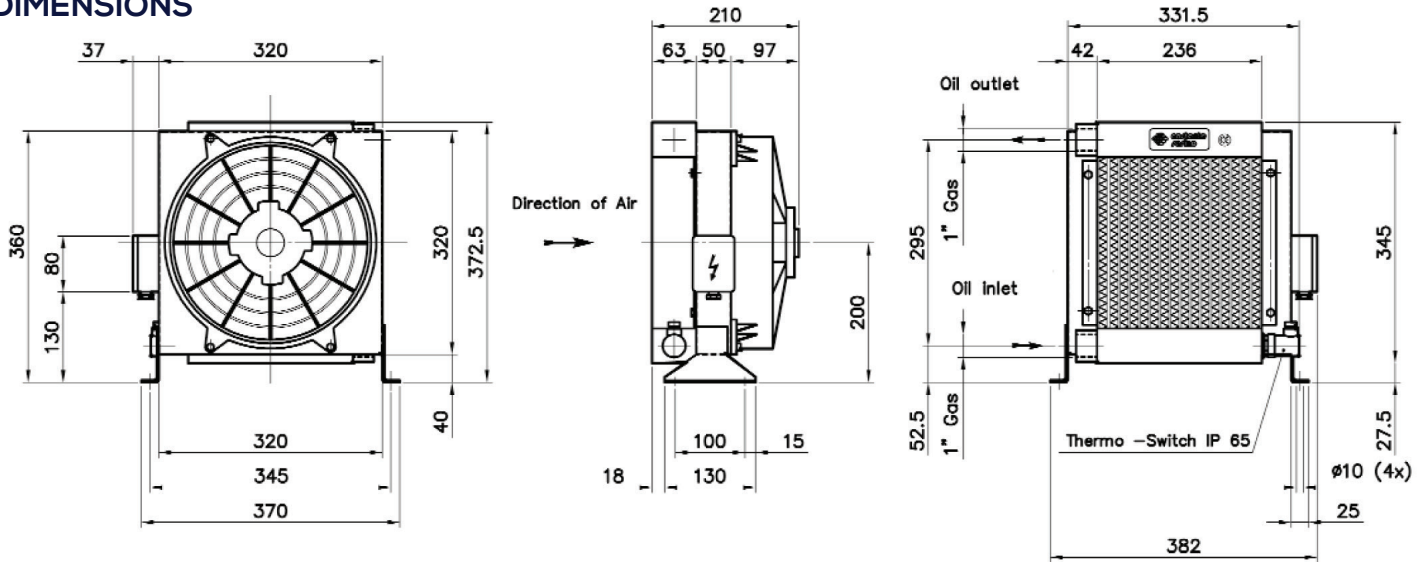

PERFORMANCE DIAGRAM

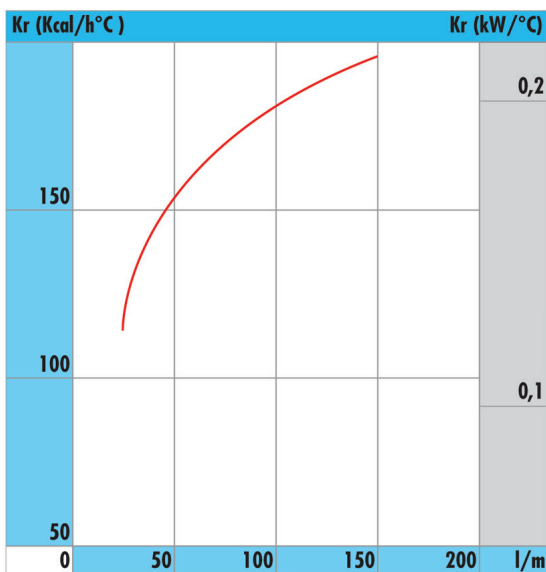

LOSS PRESSURE DIAGRAM - at 30cSt

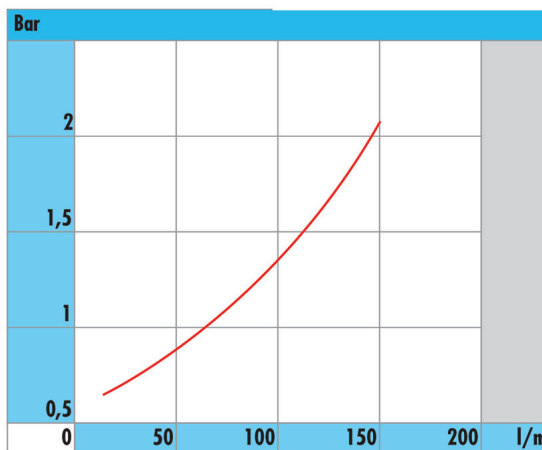

CORRECTION FACTOR

A	22	30	46	68	100	150	220	= cSt
B	0,6	1	1.5	2.3	3.5	5	7	= f

A = Oil viscosity in cSt B = Multiplication factor for pressure loss



BC 250 SERIES SINGLE PHASE / THREE PHASE

DIMENSIONS AND TECHNICAL CHARACTERISTICS ARE NOT BINDING

Type	Oil flow l/min	Capacity l	Voltage V	Frequency Hz	Power W	Current A	Air flow m3/h	Protection IP	Noise Level dB(A)	Weight Kg
BC 250 Single	25-150	2	230	50/60	120/160	0.53/0.7	950	44	73	12
BC 250 Three			230-400		105/145	0.19/0.23			75	

DIMENSIONS

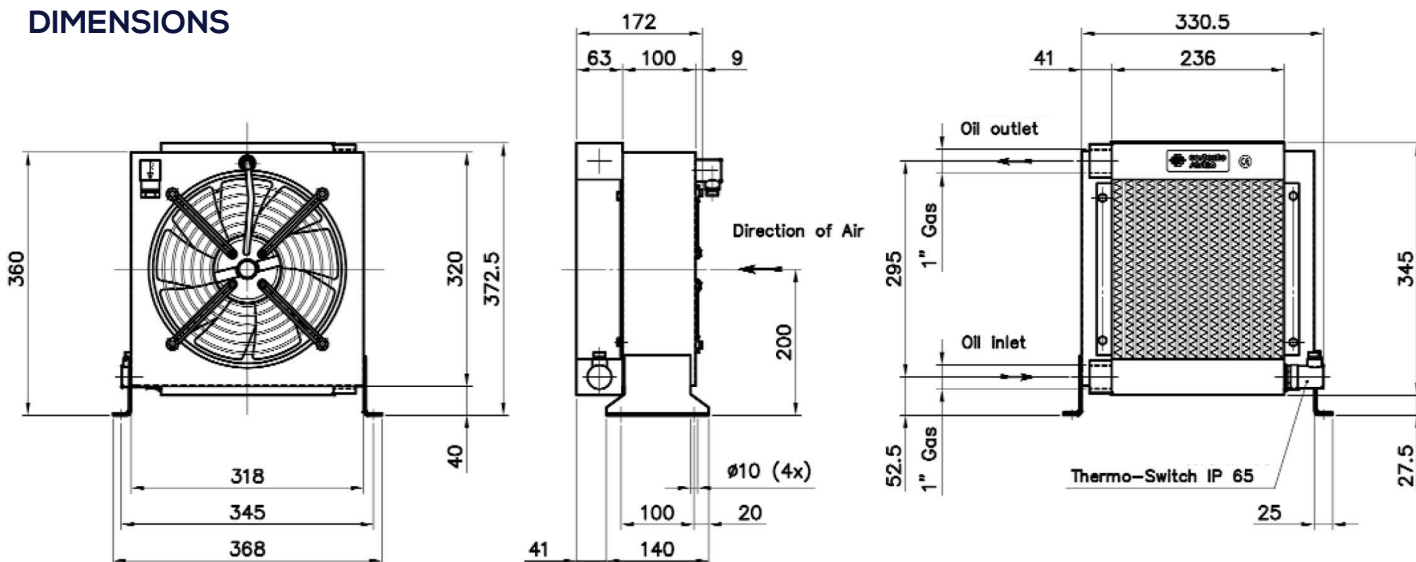

PERFORMANCE DIAGRAM

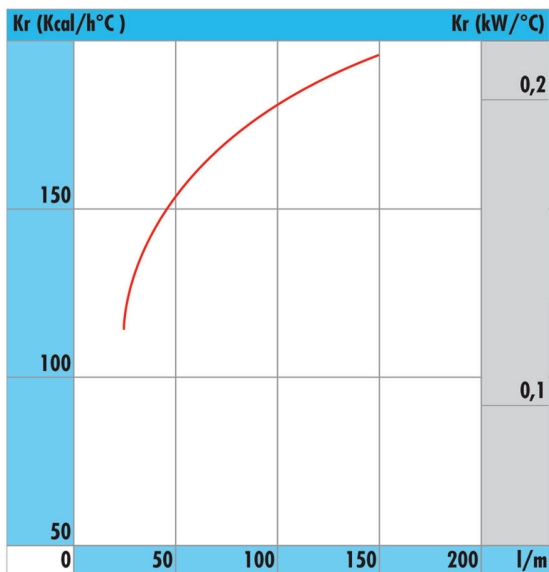

LOSS PRESSURE DIAGRAM - at 30cSt

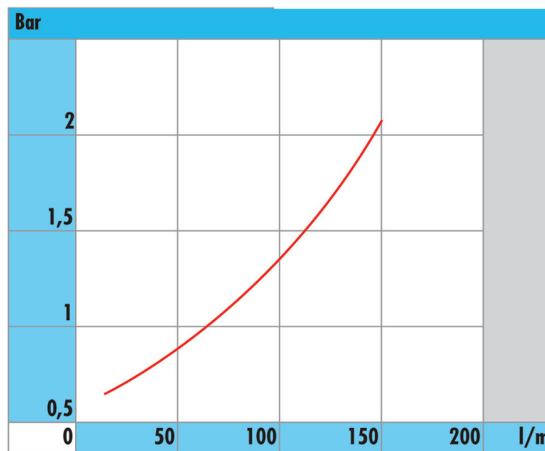

CORRECTION FACTOR

A	22	30	46	68	100	150	220	= cSt
B	0,6	1	1.5	2.3	3.5	5	7	= f

A = Oil viscosity in cSt B = Multiplication factor for pressure loss

BC 250 SERIES HYDRAULIC MOTOR



AIR BLAST COOLERS

DIMENSIONS AND TECHNICAL CHARACTERISTICS ARE NOT BINDING

Type	Oil flow l/min	Fan Speed rpm	Power W	Displacement Cc/r	Motor Flow l/min	Air flow m3/h	Noise Level dB(A)	Weight Kg	Capacity l
BC 250 I	25-150	2300	200	11.3	26	2000	68	14	2

DIMENSIONS

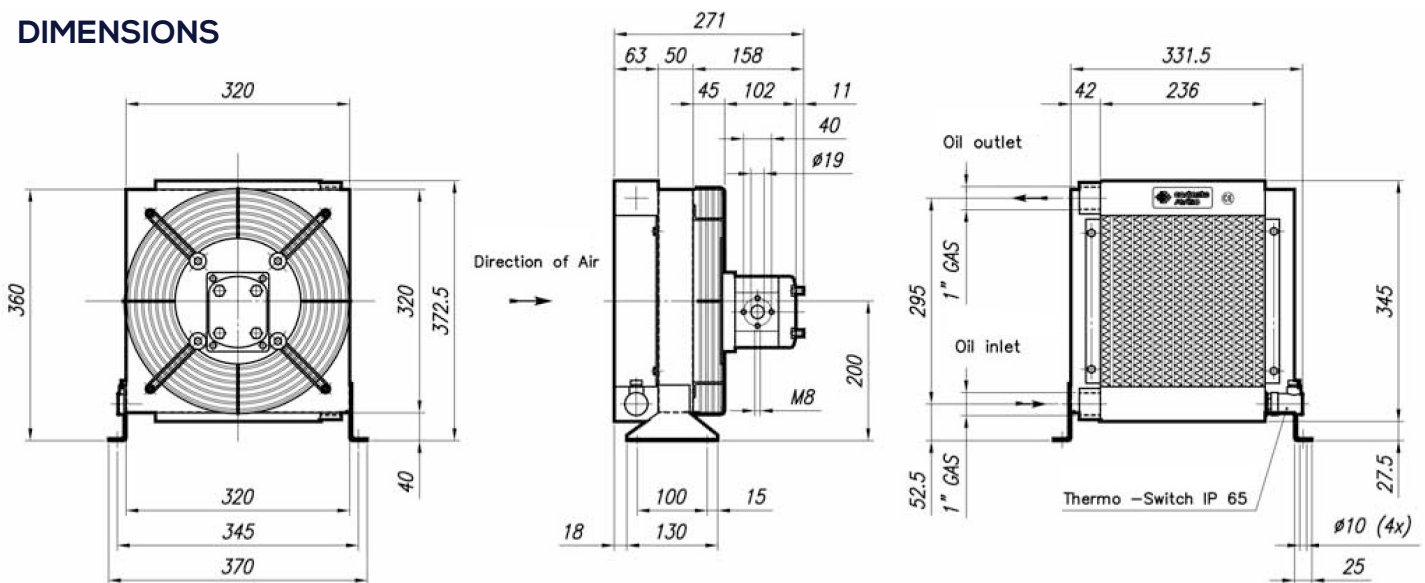

PERFORMANCE DIAGRAM

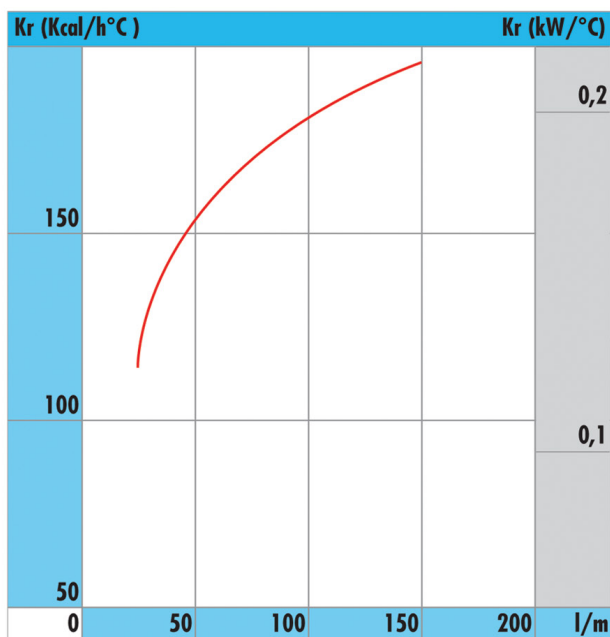

LOSS PRESSURE DIAGRAM - at 30cSt

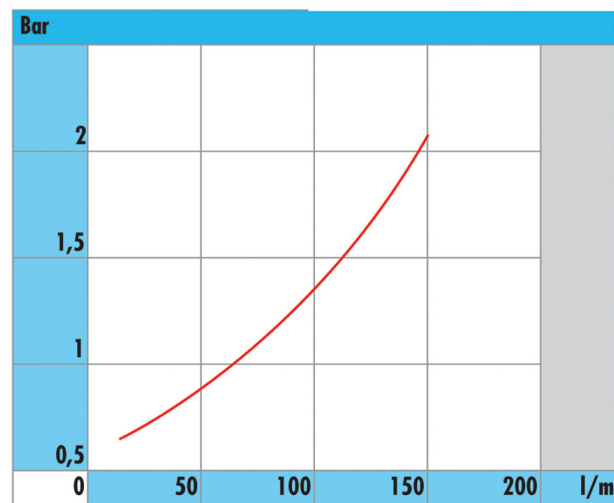

CORRECTION FACTOR

A	22	30	46	68	100	150	220	= cSt
B	0,6	1	1.5	2.3	3.5	5	7	= f

A = Oil viscosity in cSt B = Multiplication factor for pressure loss

BC 250/2 SERIES 12-24V



DIMENSIONS AND TECHNICAL CHARACTERISTICS ARE NOT BINDING

Type	Oil flow l/min	Capacity l	Voltage V	Power W	Current A	Air flow m3/h	Protection IP	Noise Level dB(A)	Weight Kg
BC 250/2 12	50-200	4	12	180	15	2.200	68	83	14
BC 250/2 24			24		7.5				

DIMENSIONS

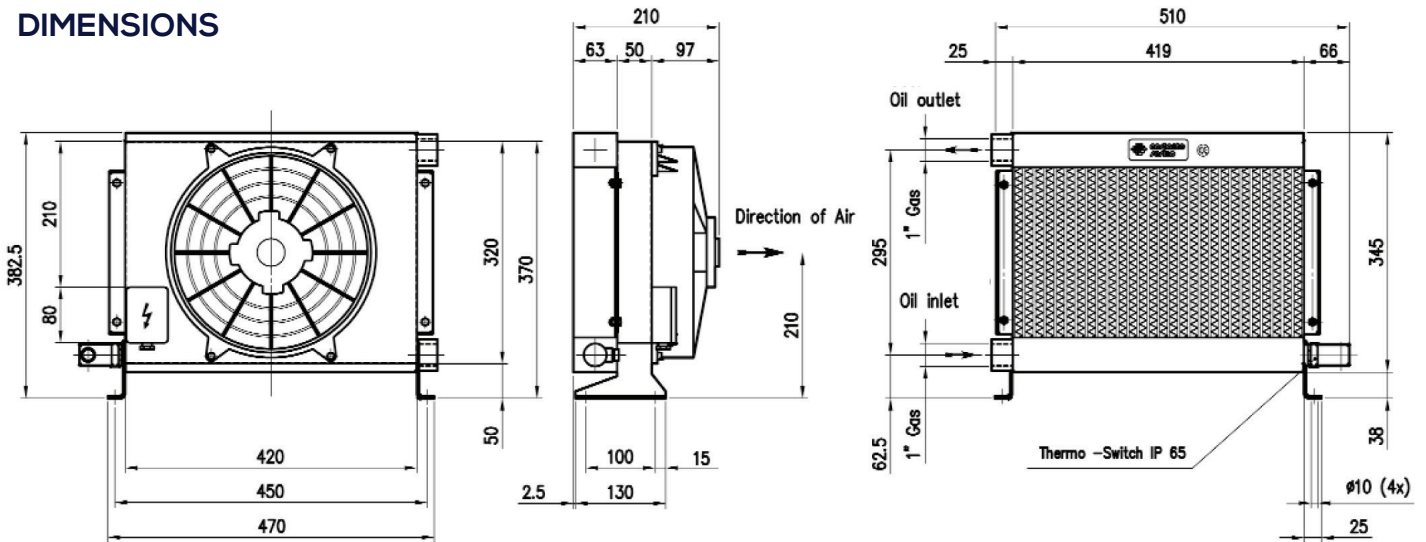

PERFORMANCE DIAGRAM

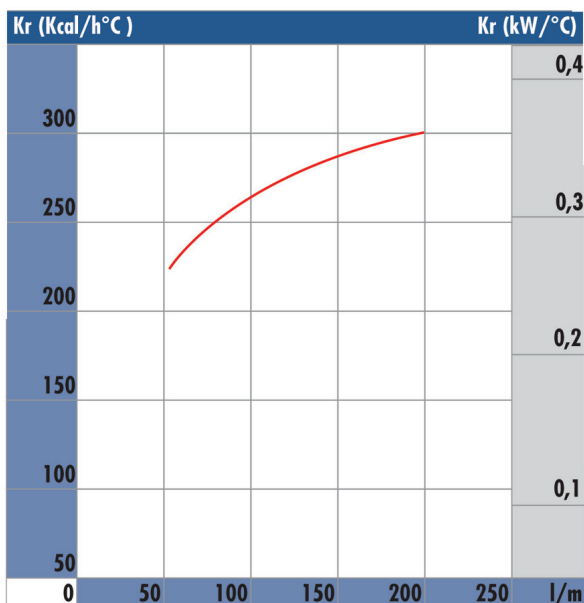

LOSS PRESSURE DIAGRAM - at 30cSt

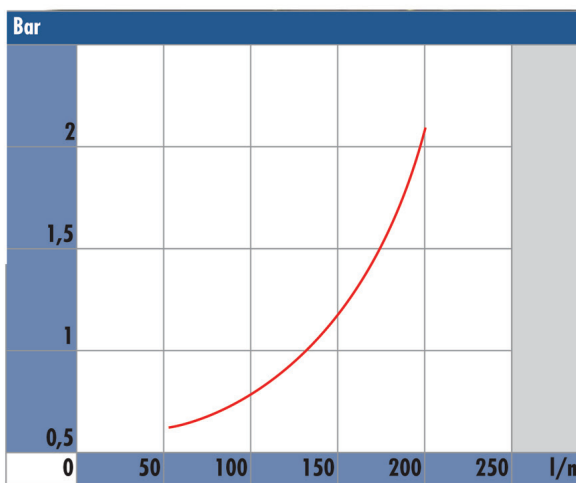

CORRECTION FACTOR

A	22	30	46	68	100	150	220	= cSt
B	0,6	1	1.5	2.3	3.5	5	7	= f

A = Oil viscosity in cSt B = Multiplication factor for pressure loss

BC 250/2 SERIES SINGLE PHASE / THREE PHASE



AIR BLAST COOLERS

DIMENSIONS AND TECHNICAL CHARACTERISTICS ARE NOT BINDING

Type	Oil flow l/min	Capacity l	Voltage V	Frequency Hz	Power W	Current A	Air flow m3/h	Protection IP	Noise Level dB(A)	Weight Kg
BC 250/2 Single	50-200	4	230	50/60	67	0.3	1.500	44	73	16
BC 250/2 Three			230-400		95/110				0.21/0.22	

DIMENSIONS

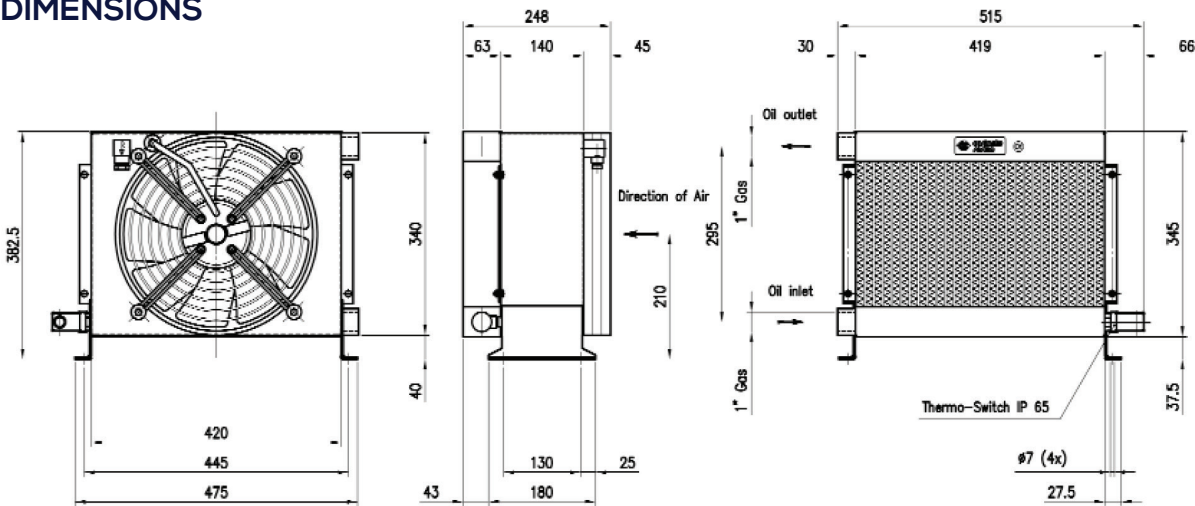

PERFORMANCE DIAGRAM

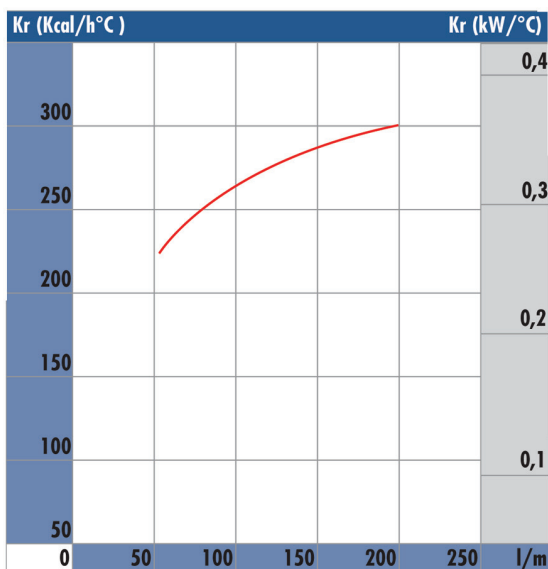

LOSS PRESSURE DIAGRAM - at 30cSt

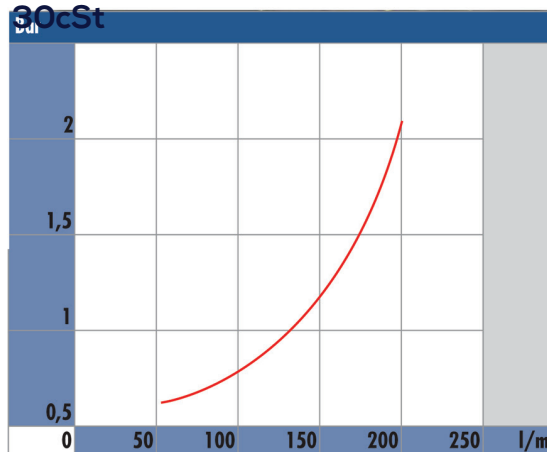

CORRECTION FACTOR

A	22	30	46	68	100	150	220	= cSt
B	0,6	1	1.5	2.3	3.5	5	7	= f

A = Oil viscosity in cSt B = Multiplication factor for pressure loss



BC 250/2 SERIES WITH HYDRAULIC MOTOR

DIMENSIONS AND TECHNICAL CHARACTERISTICS ARE NOT BINDING

Type	Oil flow l/min	Fan Speed rpm	Power W	Displacement Cc/r	Motor Flow l/min	Air flow m3/h	Noise Level dB(A)	Weight Kg	Capacity l
BC 250/2 H	25-150	2300	200	11.3	26	2500	70	19	3.6

DIMENSIONS

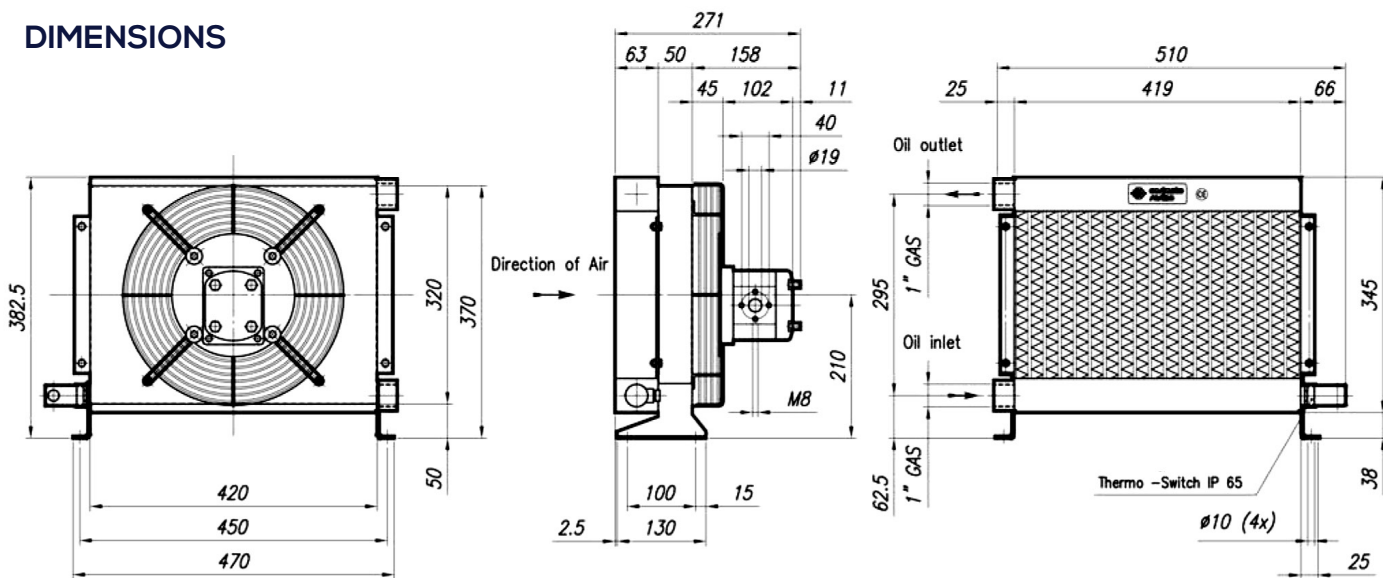

PERFORMANCE DIAGRAM

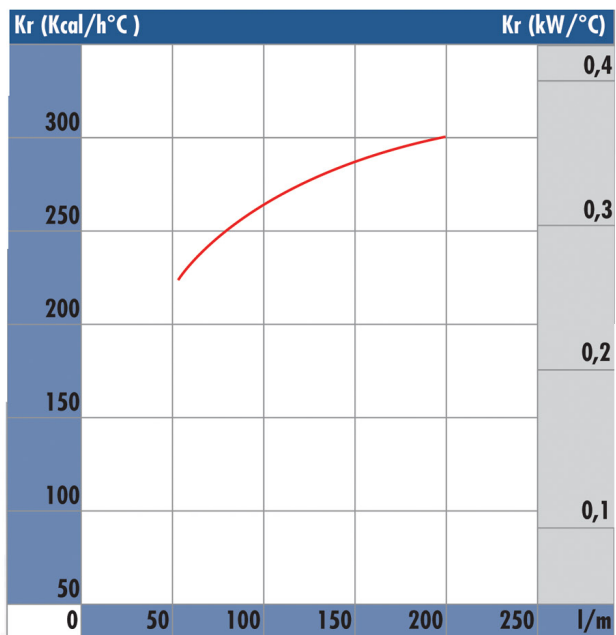

LOSS PRESSURE DIAGRAM - at 30cSt

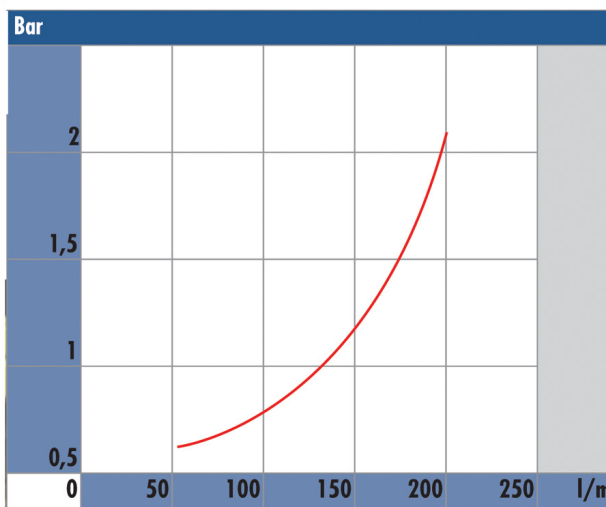

CORRECTION FACTOR

	A	22	30	46	68	100	150	220	= cSt
B	0,6	1	1.5	2.3	3.5	5	7		= f

A = Oil viscosity in cSt B = Multiplication factor for pressure loss

BC 390 SERIES 12-24V



DIMENSIONS AND TECHNICAL CHARACTERISTICS ARE NOT BINDING

Type	Oil flow l/min	Capacity l	Voltage V	Power W	Current A	Air flow m3/h	Protection IP	Noise Level dB(A)	Weight Kg
BC 390 12	50-250	5	12	240	20	2.500	68	85	16
BC 390 24			24		10				

DIMENSIONS

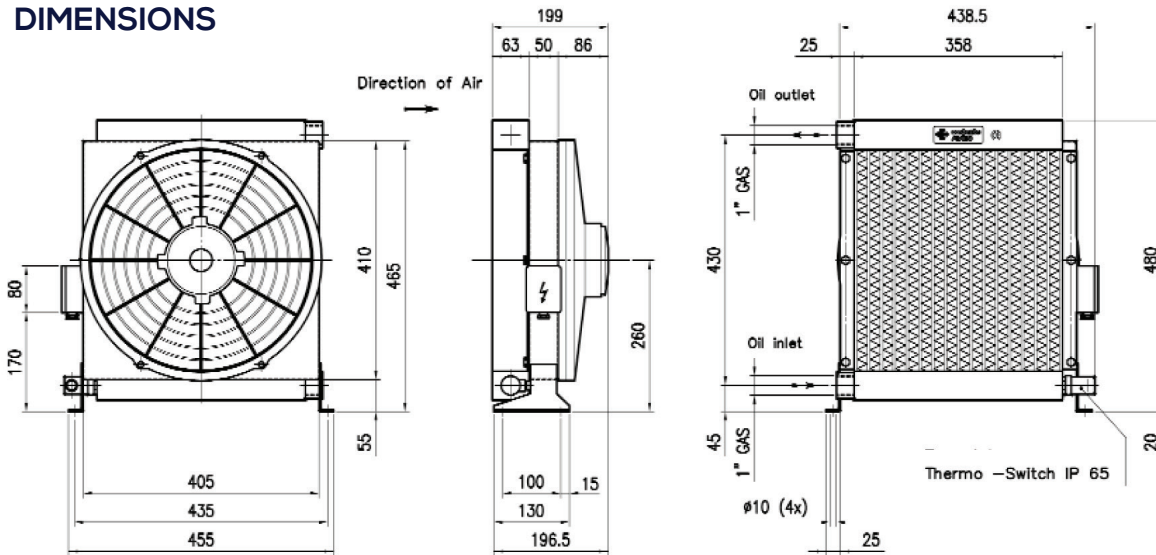

PERFORMANCE DIAGRAM

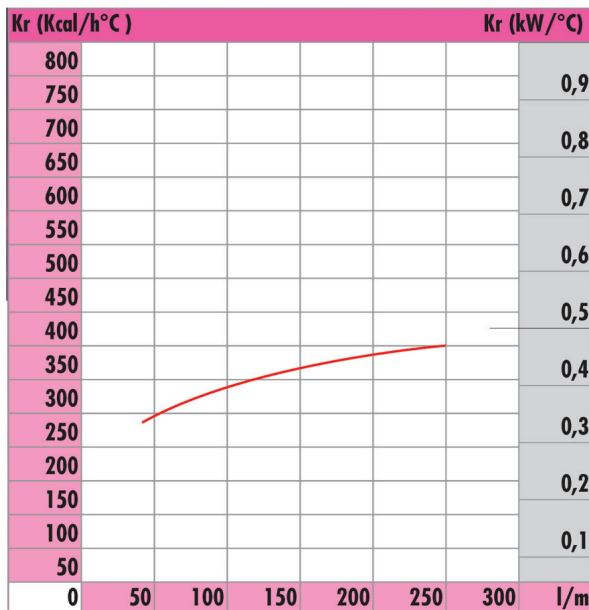

LOSS PRESSURE DIAGRAM - at 30cSt

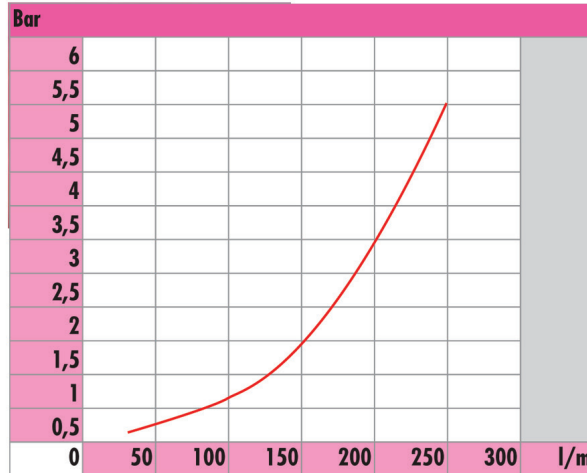

CORRECTION FACTOR

	A	22	30	46	68	100	150	220	= cSt
B	0,6	1	1,5	2,3	3,5	5	7		= f

A = Oil viscosity in cSt B = Multiplication factor for pressure loss



BC 390 SERIES SINGLE PHASE / THREE PHASE

DIMENSIONS AND TECHNICAL CHARACTERISTICS ARE NOT BINDING

Type	Oil flow l/min	Capacity l	Voltage V	Frequency Hz	Power W	Current A	Air flow m3/h	Protection IP	Noise Level dB(A)	Weight Kg
BC 390 Single	50-250	5	230	50/60	95	0.64	2.500	55	73	19
BC 390 Three			230-400		115/160					

DIMENSIONS

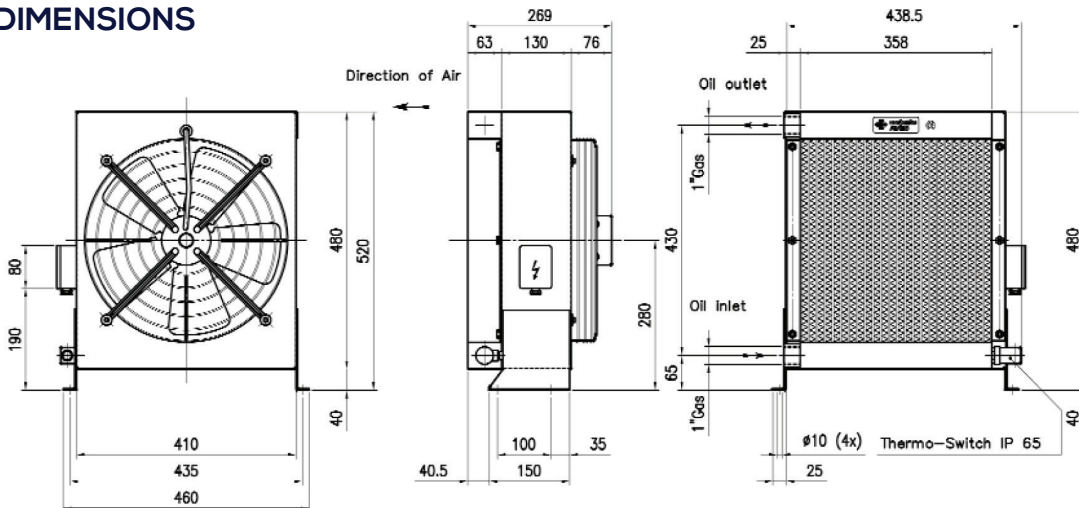

PERFORMANCE DIAGRAM

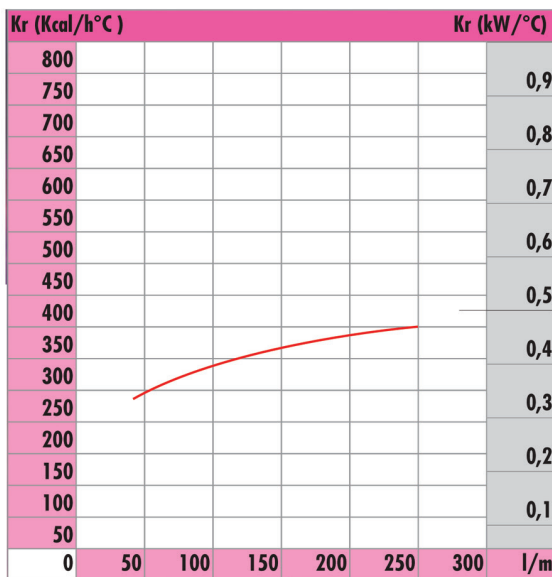

LOSS PRESSURE DIAGRAM - at 30cSt

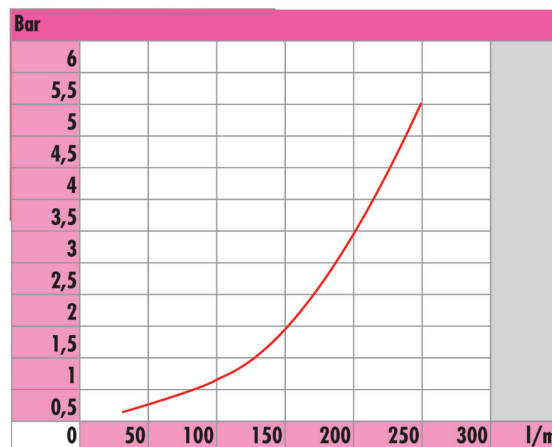

CORRECTION FACTOR

	22	30	46	68	100	150	220	= cSt
A	0,6	1	1,5	2,3	3,5	5	7	= f

A = Oil viscosity in cSt B = Multiplication factor for pressure loss

BC 390 SERIES WITH HYDRAULIC MOTOR



AIR BLAST COOLERS

DIMENSIONS AND TECHNICAL CHARACTERISTICS ARE NOT BINDING

Type	Oil flow l/min	Fan Speed rpm	Power W	Displacement Cc/r	Motor Flow l/min	Air flow m3/h	Noise Level dB(A)	Weight Kg	Capacity l
BC 390 H	50-150	2700	770	11.3	31	7000	74	23	4

DIMENSIONS

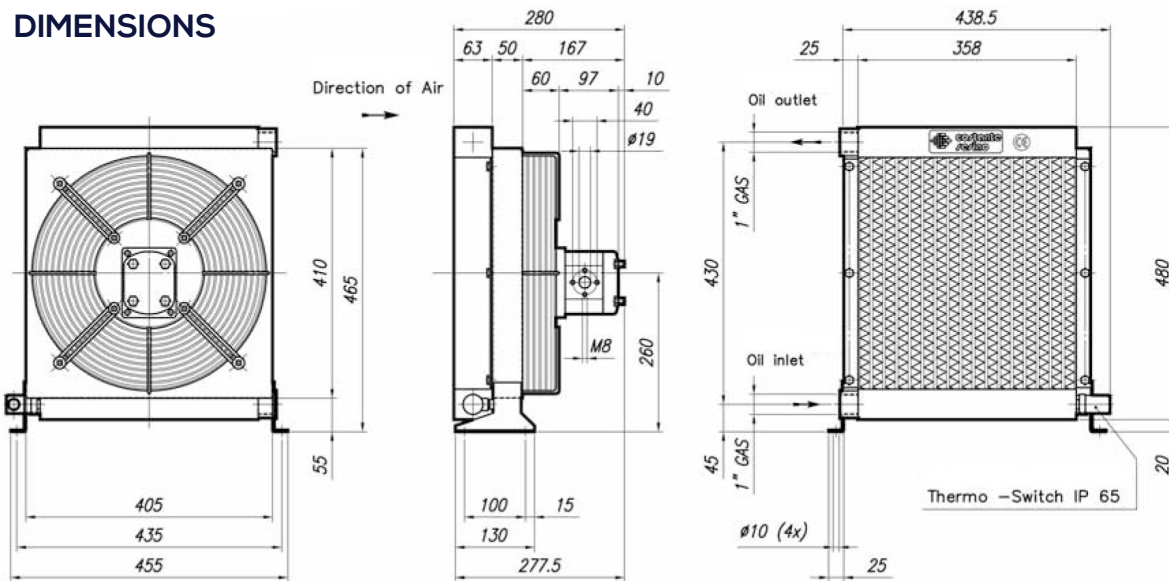

PERFORMANCE DIAGRAM

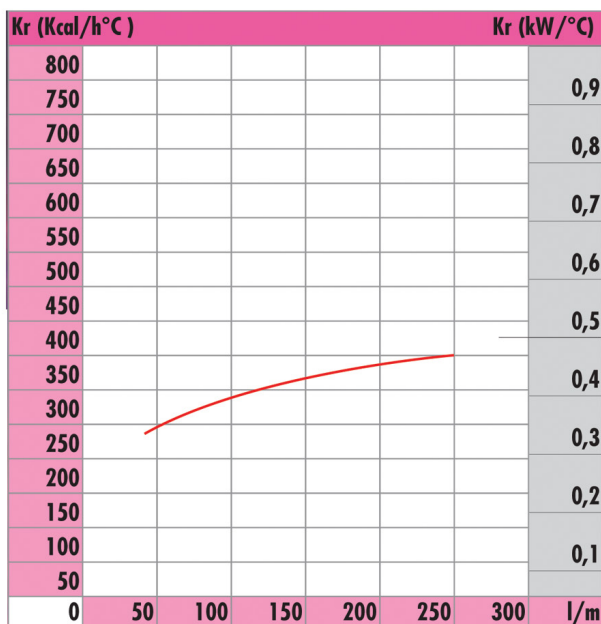

LOSS PRESSURE DIAGRAM - at 30cSt

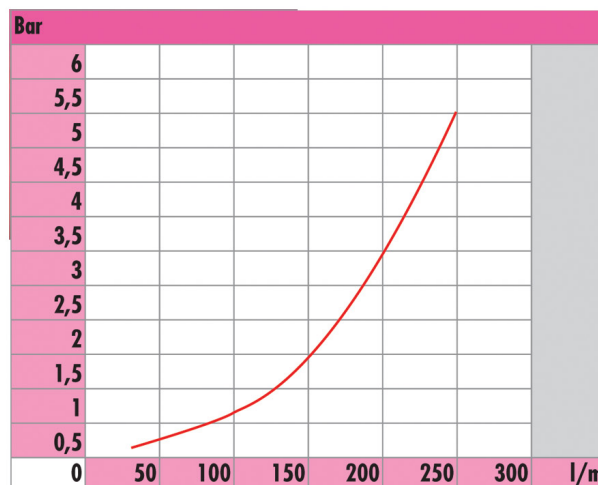

CORRECTION FACTOR

	A	22	30	46	68	100	150	220	= cSt
B	0,6	1	1.5	2.3	3.5	5	7		= f

A = Oil viscosity in cSt B = Multiplication factor for pressure loss



BC 390/2 SERIES 12-24V

DIMENSIONS AND TECHNICAL CHARACTERISTICS ARE NOT BINDING

Type	Oil flow l/min	Capacity l	Voltage V	Power W	Current A	Air flow m3/h	Protection IP	Noise Level dB(A)	Weight Kg
BC 390/2 12	50-300	8	12	240	20	2.800	68	86	25
BC 390/2 24			24		10				

DIMENSIONS

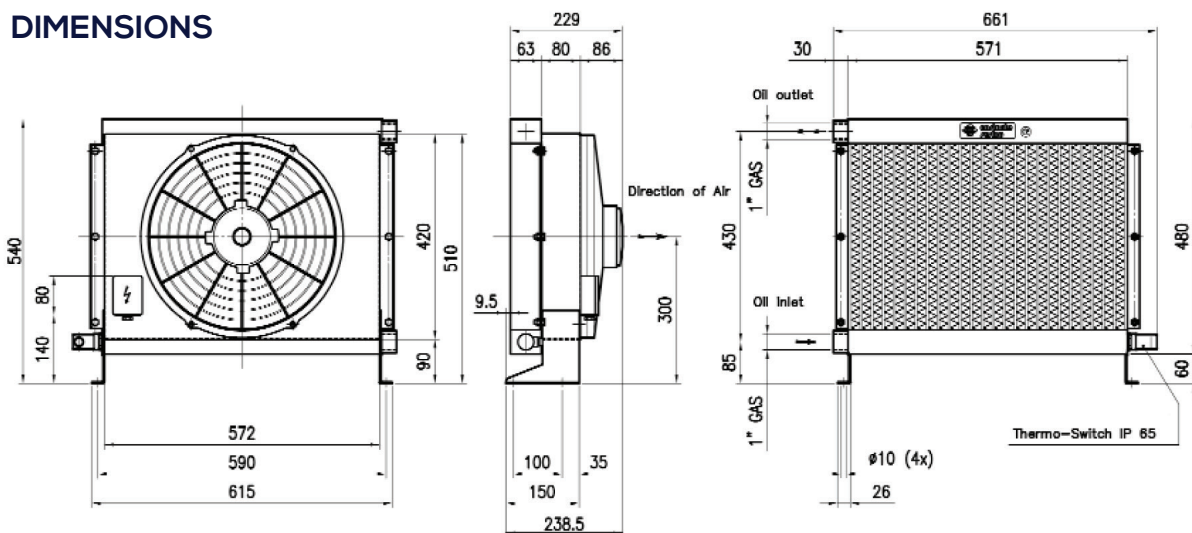

PERFORMANCE DIAGRAM

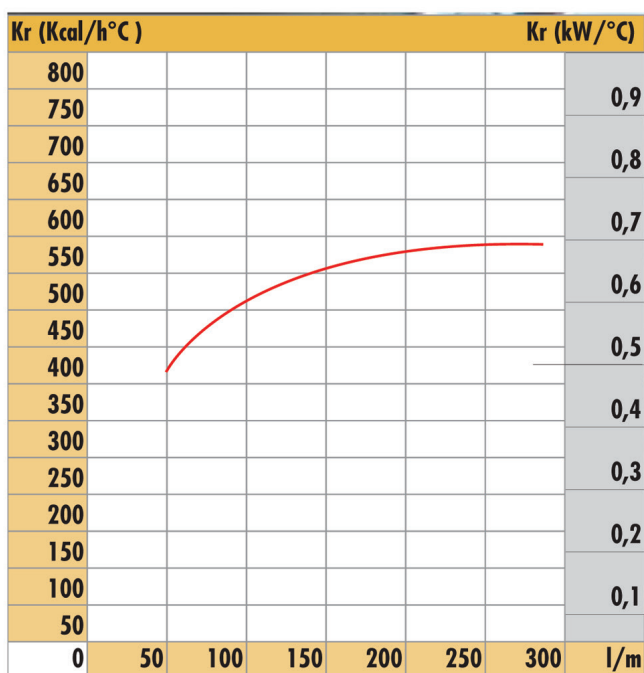

LOSS PRESSURE DIAGRAM - at 30cSt

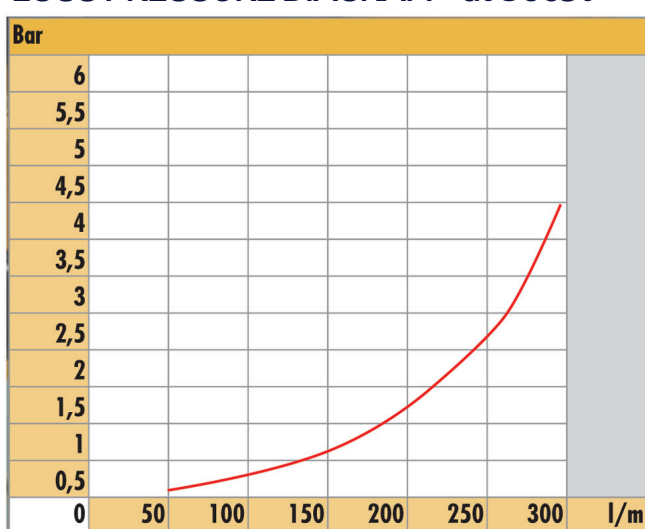

CORRECTION FACTOR

A	22	30	46	68	100	150	220	= cSt
B	0,6	1	1.5	2.3	3.5	5	7	= f

A = Oil viscosity in cSt B = Multiplication factor for pressure loss

BC 390/2 SERIES SINGLE PHASE / THREE PHASE



AIR BLAST COOLERS

DIMENSIONS AND TECHNICAL CHARACTERISTICS ARE NOT BINDING

Type	Oil flow l/min	Capacity l	Voltage V	Frequency Hz	Power W	Current A	Air flow m3/h	Protection IP	Noise Level dB(A)	Weight Kg
BC 390/2 Single	50-300	8	230	50/60	310	1.35	2.500	55	73	30
BC 390/2 Three			230-400		145/140	0.77/0.45	2.900			

DIMENSIONS

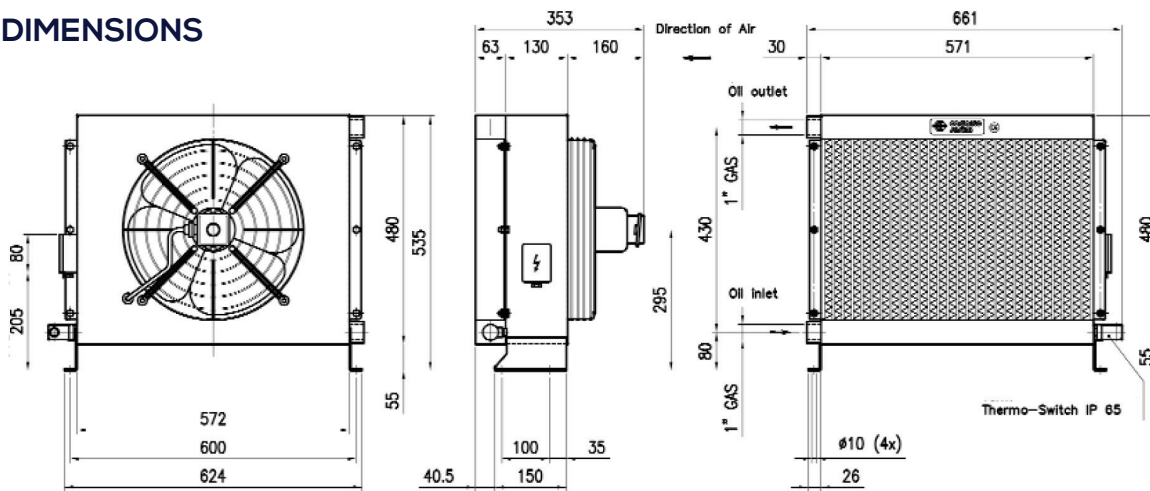

PERFORMANCE DIAGRAM

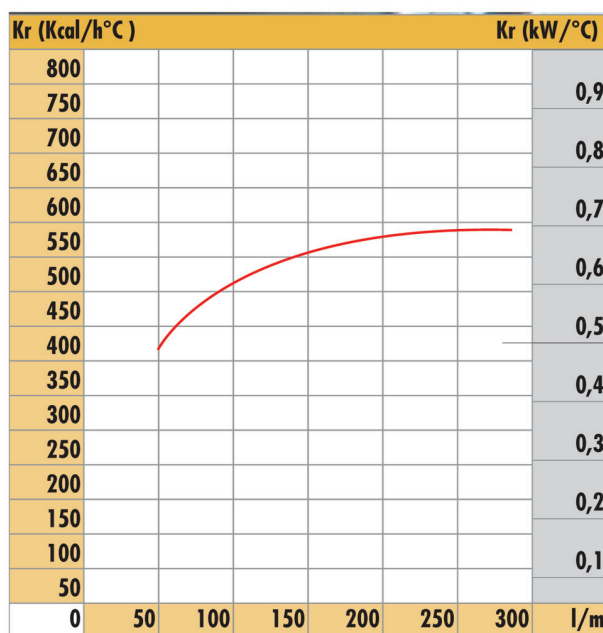

LOSS PRESSURE DIAGRAM - at 30cSt

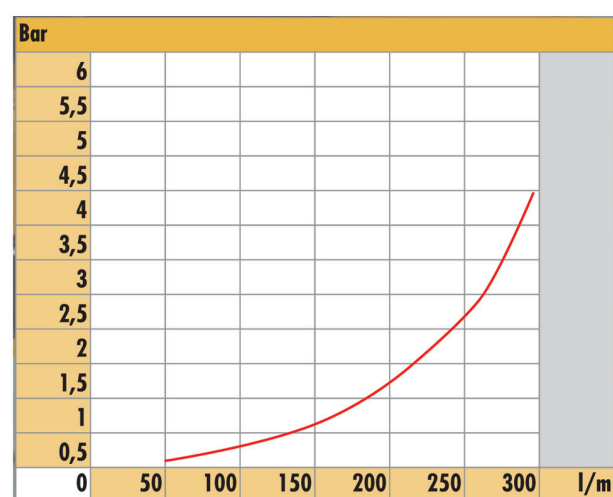

CORRECTION FACTOR

A	22	30	46	68	100	150	220	= cSt
B	0,6	1	1,5	2,3	3,5	5	7	= f

A = Oil viscosity in cSt B = Multiplication factor for pressure loss



BC 390/2 SERIES WITH HYDRAULIC MOTOR

DIMENSIONS AND TECHNICAL CHARACTERISTICS ARE NOT BINDING

Type	Oil flow l/min	Fan Speed rpm	Power W	Displacement Cc/r	Motor Flow l/min	Air flow m3/h	Noise Level dB(A)	Weight Kg	Capacity l
BC 390/2 H	50-300	2700	830	11.3	31	9000	76	25	6

DIMENSIONS

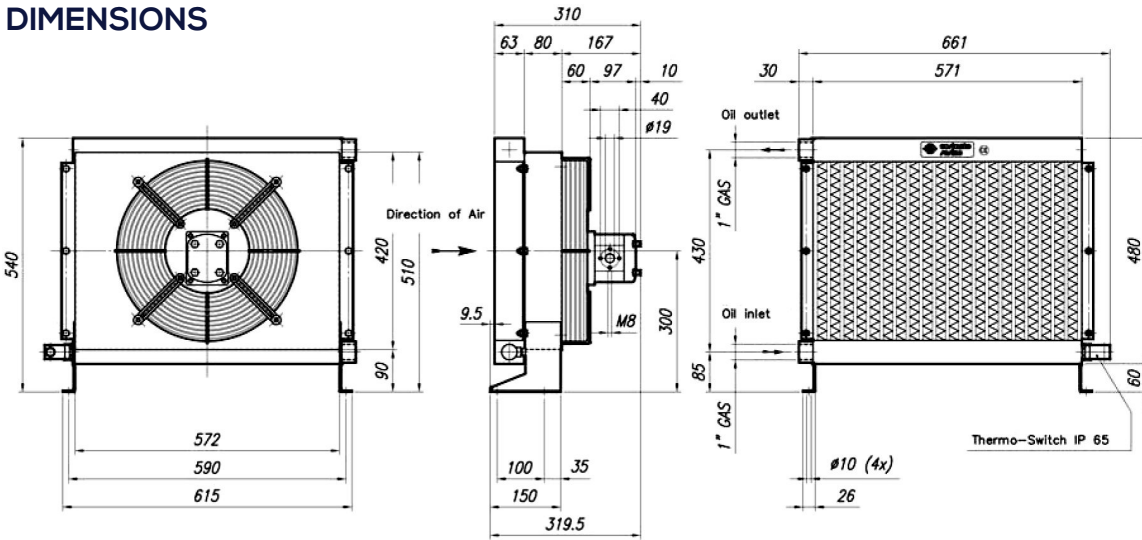

PERFORMANCE DIAGRAM

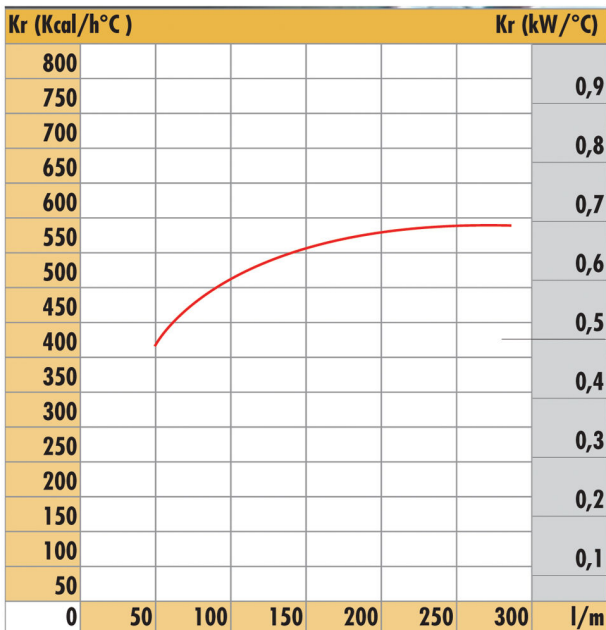

LOSS PRESSURE DIAGRAM - at 30cSt

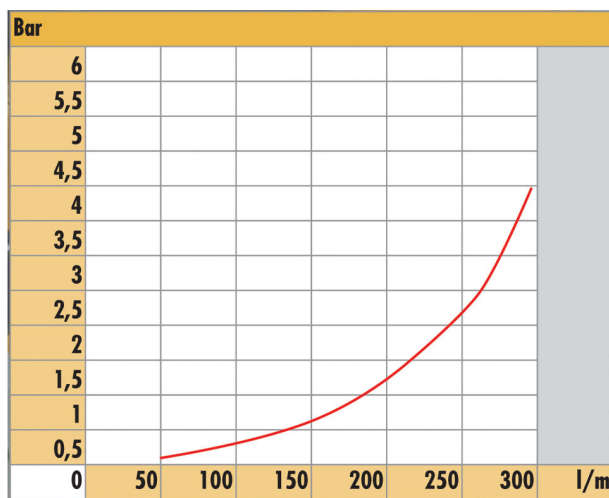

CORRECTION FACTOR

A	22	30	46	68	100	150	220	= cSt
B	0,6	1	1.5	2.3	3.5	5	7	= f

A = Oil viscosity in cSt B = Multiplication factor for pressure loss