

STEAM DISTRIBUTION MANIFOLD MAS

DESCRIPTION

The MAS series steam distribution manifolds are essentially designed to allow the placement of steam supply valves in a single location, reducing costs and providing an easy control of different steam lines.

The drain connection, with an automatic steam trap installed, discharges any condensate formed, thus providing high quality dry steam.

MAIN FEATURES

Several installation possibilities.

Reduced field assembly costs, achieved by means of prefabrication.

OPTIONS: Complete units including valves, pressure gauges and steam trap station.
 Different designs.

USE: Saturated or superheated steam.
 Water, compressed air and other fluids (on request).

AVAILABLE MODELS: MAS-H – horizontal steam distribution manifold.
 MAW-H – horizontal liquid manifold.
 MAG-H – horizontal gas manifold.

SIZES: DN 100 to DN 300.

CONNECTIONS: Flanged EN 1092-1 PN 16 or PN 40.
 Flanged ASME B16.5 Class 150 or 300.
 Female threaded ISO 7 Rp or NPT on request.

DESIGN CODE: AD Merkblatt.

INSTALLATION: Always with the condensate connection pointing downwards.
 See IMI – Installation and maintenance instructions.

INQUIRY INFORMATION: Type of fluid, maximum operating pressure and temperature.
 Manifold diameter (dimension B).
 Number of connections from left to right using suffix “I” and “O” to identify the inlets and outlets.
 Example: MAS-H B-168 with 1 DN100-I + 2 DN50-O + 1 DN40-O.
 Condensate connection d1.
 Other relevant information like insulation thickness, instrumentation connections, etc.
 Note: In case of order, an approval drawing shall be sent before manufacturing.

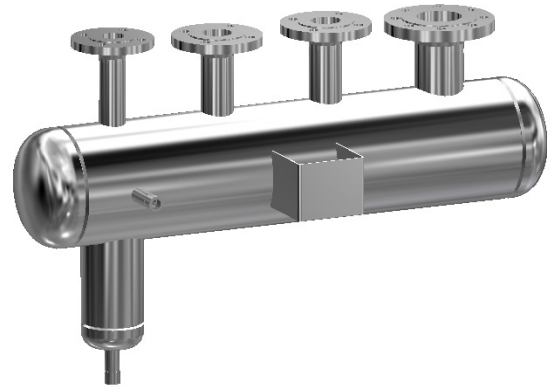

CE MARKING – GROUP 2 (PED – European Directive)

Since this is not a standard product, and can have different volumes and operation conditions, the conformity assessment and CE marking has to be carried out case by case.

MATERIALS	
DESIGNATION	MATERIAL
Body	P235GH / 1.0325
Heads	P265GH / 1.0425
Inlet / Outlet pipes	P235GH / 1.0325
EN flanges	P250GH / 1.0460
ASME flanges	ASTM A105 / 1.0432
Sockets	ASTM A105 / 1.0432
* Internals	S235JR / 1.0038

* If any.

FLANGE CONNECTIONS			
RATING	SIZE	EN STANDARD	ASME STANDARD
PN 16	* DN 15 to DN 50	EN 1092-1 PN 40	ASME B16.5 Cl. 150
PN 16	DN 65 to DN 300	EN 1092-1 PN 16	ASME B16.5 Cl. 150
PN 25	DN 15 to DN 150	EN 1092-1 PN 40	ASME B16.5 Cl. 300
PN 25	DN 200 to DN 300	EN 1092-1 PN 25	ASME B16.5 Cl. 300
PN 40	DN 15 to DN 300	EN 1092-1 PN 40	ASME B16.5 Cl. 300

* Flanges EN 1092-1 PN 16 and PN 40, from DN 15 to DN 50, have the same number and size of holes.

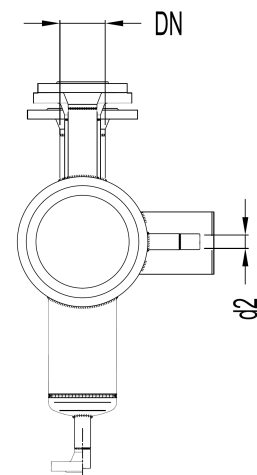
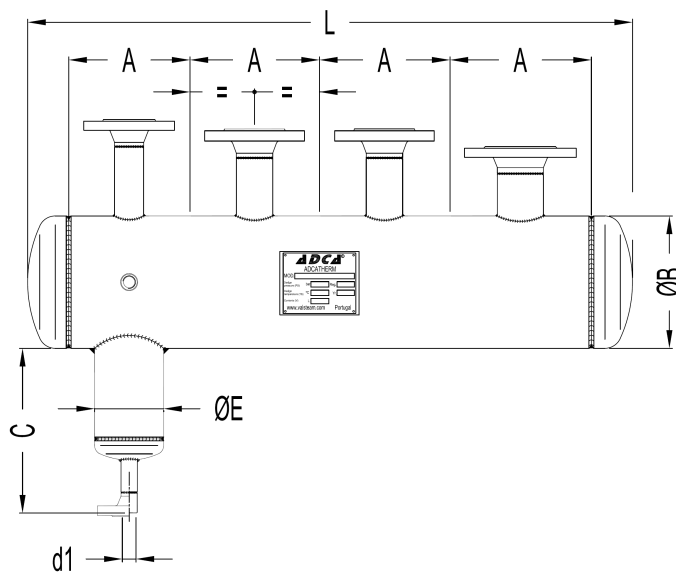

SUGGESTED DIMENSIONS *														
DN	15	20	25	32	40	50	65	80	100	125	150	200	250	300
A (mm)	145	155	165	190	200	215	235	250	270	300	335	395	455	510

* Recommended minimum gap between flanged connections for later assembly of EN 1092-1 PN 16 / PN 40 flanged globe valves.

Remark: Since this is not a standard product, and can have different volumes and sizes, the certified values for each dimension will be supplied only after complete data evaluation and order confirmation

MAXIMUM BRANCH CONNECTION DEPENDING ON DIAMETER "B" (mm)							
B	114	140	168	220	275	325	357
DN	≤ 65	≤ 80	≤ 100	≤ 150	≤ 200	≤ 200	≤ 250

TYPICAL INSTALLATIONS

MATERIALS	
POS. N°	DESIGNATION
1	MAS-H – Manifold
2	BM32 – Bimetallic steam trap
3	VF16 – Bellow seal valve
5	DW40S – Sight glass
6	RD40 – Check valve
7	GSC-40 – Gauge siphon
8	GC-400 – Gauge cock
9	MAN-100 – Pressure gauge

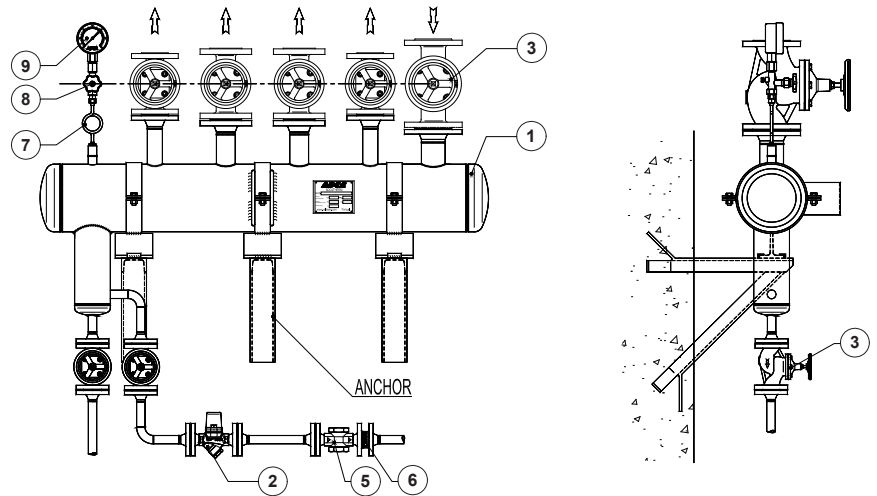

MATERIALS	
POS. N°	DESIGNATION
1	MAS-H – Manifold
2	IB12 – Inverted bucket trap
3	VF16 – Bellow seal valve
4	GV32B – Globe valve
5	SW12 – Sight glass
6	RT25 – Check valve
7	GSU-40 – Gauge siphon
8	GC-400 – Gauge cock
9	MAN-100 – Pressure gauge

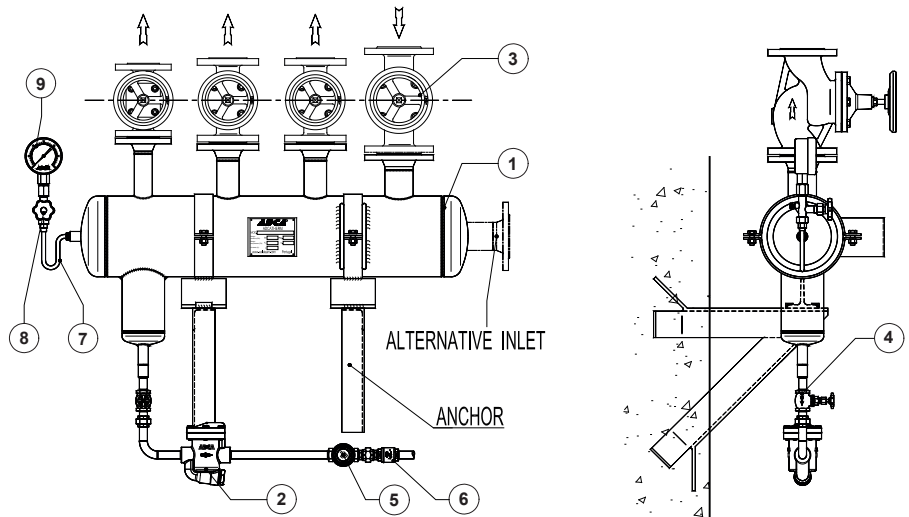

MATERIALS	
POS. N°	DESIGNATION
1	MAS-H – Manifold
2	FLT17LC – Float steam trap *
3	VF16 – Bellow seal valve
4	GV32B – Globe valve
5	SCK – Sight checker
6	IS16 – Y strainer
7	GSU-40 – Gauge siphon
8	GC-400 – Gauge cock
9	MAN-100 – Pressure gauge

*Recommended for low pressures only.

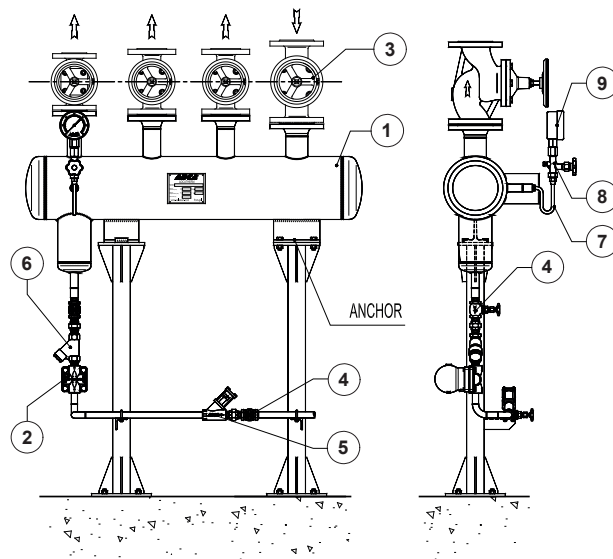

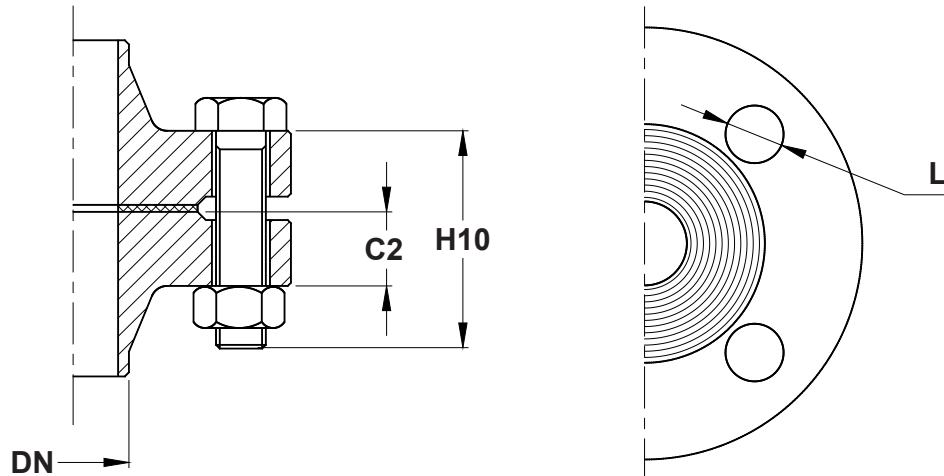

BOLTING DIMENSIONS FOR FLANGES

SIZE	EN 1092-1 TYPE 11 PN 16					EN 1092-1 TYPE 11 PN 25					EN 1092-1 TYPE 11 PN 40				
	C2	ØL	BOLTING		H10	C2	ØL	BOLTING		H 10	C2	ØL	BOLTING		H10
			N°	SIZE				N°	SIZE				N°	SIZE	
DN 15	16	14	4	M12	50	16	14	4	M12	50	16	14	4	M12	50
DN 20	18	14	4	M12	55	18	14	4	M12	55	18	14	4	M12	55
DN 25	18	14	4	M12	55	18	14	4	M12	55	18	14	4	M12	55
DN 32	18	18	4	M16	55	18	18	4	M16	55	18	18	4	M16	55
DN 40	18	18	4	M16	55	18	18	4	M16	55	18	18	4	M16	55
DN 50	18	18	4	M16	55	20	18	4	M16	60	20	18	4	M16	60
DN 65	18	18	4 *	M16	55	22	18	8	M16	65	22	18	8	M16	65
DN 80	20	18	8	M16	60	24	18	8	M16	70	24	18	8	M16	70
DN 100	20	18	8	M16	60	24	22	8	M20	75	26	22	8	M20	75
DN 125	22	18	8	M16	65	26	26	8	M24	80	28	26	8	M24	90
DN 150	22	22	8	M20	70	28	26	8	M24	90	30	26	8	M24	90
DN 200	24	22	12	M20	75	30	26	12	M24	90	36	30	12	M27	110
DN 250	26	26	12	M24	80	32	30	12	M27	100	42	33	12	M30	120
DN 300	28	26	12	M24	90	34	30	16	M27	100	52	33	16	M30	140

* Flange EN 1092-1 DN 65 PN 16 with 4 holes as standard. Flange with 8 holes under request.