

**SHELL AND TUBE HEAT EXCHANGERS  
STV  
(Steam to water – Vertical installation)**

**DESCRIPTION**

The ADCA ST series steam to water shell and tube heat exchangers are shorter and lighter than the alternative shell and tube exchangers manufactured with smooth pipes. The use of extruded low fin tubes has the advantage that it can improve the external surface and thermal performance.

**MAIN FEATURES**

Corrosion-resistant stainless steel low finned tube bundle construction.  
Straight tubes for easy cleaning.  
Floating head at the end of the tube bundle, avoiding tube stresses caused by thermal expansion and contraction.

**USE:** Steam, water, hot condensate and other fluids compatible with the construction.

**AVAILABLE**

**MODELS:** STV/S – carbon steel shell.  
STV/SS – completely in stainless steel.

**CONNECTIONS:** Flanged EN 1092-1 PN 16.  
Flanged ASME B16.5 Class 150.  
Female threaded ISO 7 Rp or NPT.

**INSTALLATION:** Wall mounting or floor (needs special supports).  
Steam runs inside the tubes and process water outside.  
See IMI – Installation and maintenance instructions.

**ORDER**

**REQUIREMENTS:** Steam pressure and temperature.  
Inlet and outlet water temperature.  
Water mass flow or heat exchanged.



CE MARKING – GROUP 2 (PED – European Directive)		
PN16	Category Tube side	Category Shell side
STV4.075 to 4.150	1 (CE marked)	SEP
STV5.075 to 5.150	1 (CE marked)	SEP
STV6.075 to 6.150	1 (CE marked)	SEP
STV8.075 to 8.150	2 (CE marked)	SEP
STV10.075 to 10.150	2 (CE marked)	SEP
STV12.075 to 12.150	2 (CE marked)	SEP

BODY LIMITING CONDITIONS *			
PN 16		CLASS 150	
ALLOWABLE PRESSURE	RELATED TEMPERATURE	ALLOWABLE PRESSURE	RELATED TEMPERATURE
16 bar	50 °C	16 bar	50 °C
15 bar	100 °C	15 bar	100 °C
12,7 bar	200 °C	12,6 bar	200 °C
12 bar	250 °C	–	–

Min. operating temp.: -10 °C; Design code: AD-Merkblatt.

\* Rating according to EN 1092-1:2018.

PMO – Maximum operating pressure for saturated steam: 13 bar.

MATERIALS		
DESIGNATION	STV/S	STV/SS
Tube bundle	AISI 316L / 1.4404	AISI 316L / 1.4404
Tube sheet	AISI 316 / 1.4401	AISI 316 / 1.4401
Heads	S235JRG2 / 1.0038; P235GH / 1.0345	AISI 316 / 1.4401; AISI 316L / 1.4404
Inlet / outlet pipes	P235GH / 1.0345	AISI 316 / 1.4401
EN flanges	P250GH / 1.0460	AISI 316 / 1.4401
ASME flanges	ASTM A105 / 1.0432	AISI 316 / 1.4401
Sockets	ASTM A105 / 1.0432	AISI 316 / 1.4401
Supports	S235JRG2 / 1.0038	AISI 304 / 1.4301

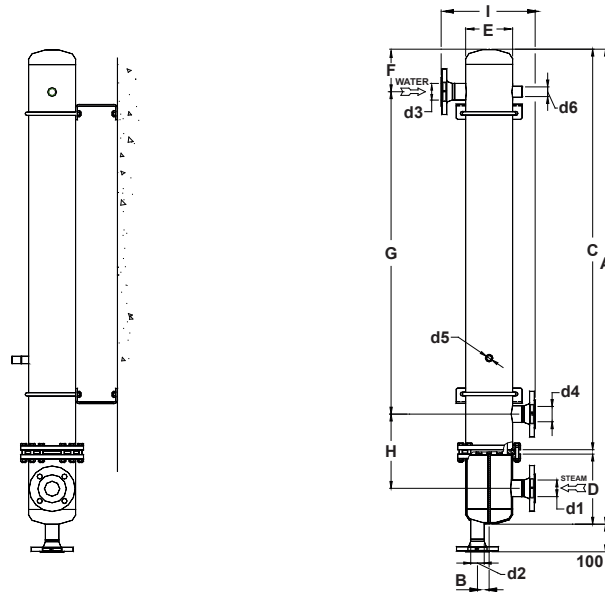

DIMENSIONS (mm)															
MODEL	A	B	C	D	E	F	G	H	I	d1 *	d2 *	d3 *	d4 *	d5	d6
STV4.075	965	28	785	166	114	120	550	207	314	DN 50	DN 25	DN 50	DN 50	1/2"	3/4"
STV4.100	1215	28	1035	166	114	120	800	207	314	DN 50	DN 25	DN 50	DN 50	1/2"	3/4"
STV4.150	1715	28	1535	166	114	120	1300	207	314	DN 50	DN 25	DN 50	DN 50	1/2"	3/4"
STV5.075	1050	35	790	245	140	160	510	276	340	DN 65	DN 40	DN 65	DN 65	1/2"	3/4"
STV5.100	1300	35	1040	245	140	160	760	276	340	DN 65	DN 40	DN 65	DN 65	1/2"	3/4"
STV5.150	1800	35	1540	245	140	160	1260	276	340	DN 65	DN 40	DN 65	DN 65	1/2"	3/4"
STV6.075	1093	40	820	255	168	180	500	288	368	DN 65	DN 40	DN 65	DN 65	1/2"	3/4"
STV6.100	1343	40	1070	255	168	180	750	288	368	DN 65	DN 40	DN 65	DN 65	1/2"	3/4"
STV6.150	1843	40	1570	255	168	180	1250	288	368	DN 65	DN 40	DN 65	DN 65	1/2"	3/4"
STV8.075	1176	55	840	320	220	197	487	304	420	DN 80	DN 50	DN 80	DN 80	1/2"	1"
STV8.100	1426	55	1090	320	220	197	737	304	420	DN 80	DN 50	DN 80	DN 80	1/2"	1"
STV8.150	1926	55	1590	320	220	197	1237	304	420	DN 80	DN 50	DN 80	DN 80	1/2"	1"
STV10.075	1185	60	855	306	273	205	448	356	473	DN 80	DN 50	DN 80	DN 80	1/2"	1"
STV10.100	1435	60	1105	306	273	205	698	356	473	DN 80	DN 50	DN 80	DN 80	1/2"	1"
STV10.150	1935	60	1605	306	273	205	1198	356	473	DN 80	DN 50	DN 80	DN 80	1/2"	1"
STV12.075	1307	80	877	407	324	277	400	430	540	DN 100	DN 50	DN 100	DN 100	1/2"	1"
STV12.100	1557	80	1127	407	324	277	650	430	540	DN 100	DN 50	DN 100	DN 100	1/2"	1"
STV12.150	2057	80	1627	407	324	277	1150	430	540	DN 100	DN 50	DN 100	DN 100	1/2"	1"

\* Merely indicative values. Final sizes will be determined after order, considering the effective flow rates and connections.  
Pipe connections are sized considering the correct thermal insulation, not included but recommended to be applied after the installation.