

PRESSURE OPERATED PUMP POP (4" x 4" – DN 100 x 100)

DESCRIPTION

The ADCAMat POP pressure operated pump is recommended in the transfer of steam condensate, oils and other non-hazardous liquids compatible with the construction, to a higher elevation or pressure. Under certain conditions, it can drain a closed vessel under vacuum or pressure.

The pump can be operated using steam, compressed air or other gases, and is manufactured in carbon steel.

OPERATION

Liquid flows by gravity into the pump through an inlet check valve, lifting the float. At this point, the motive fluid intake valve is closed while the vent valve is open. As the float reaches its highest position the motive fluid intake valve opens and the vent valve closes, allowing the motive fluid to enter the pump body. The pressure in the pump builds up just enough to overcome backpressure.

The pressurized liquid opens the outlet check valve and the discharge starts. The liquid discharged may be quantified through a special counter, enabling the pump to function as a reliable flow meter.

When the float reaches its lower position the motive fluid intake valve closes and the vent valve opens allowing the liquid to fill the pump once again, repeating the cycle.

MAIN FEATURES

- Hardened stainless steel wear parts.
- High-endurance inconel springs.
- Low filling head to minimize installation space.
- No electric requirements or NPSH issues.
- Suitable for hazardous environments.
- Low running costs.

OPTIONS: Level gauge.
Stroke counters.

USE: To lift steam condensate and other liquids compatible with the construction.

AVAILABLE MODELS: POPS – carbon steel.

SIZES: 4" x 4"; DN 100 x 100

CONNECTIONS: Flanged EN 1092-1 PN 16.
Flanged ASME B16.5 Class 150.
Female threaded ISO 7 Rp (threaded flanges).
Others on request.

INSTALLATION: Horizontal installation. An example is shown in Fig. 1. See IMI – Installation and maintenance instructions.

MOTIVE MEDIUM: Saturated steam, compressed air, nitrogen and other gases.



BODY LIMITING CONDITIONS *		
	ALLOWABLE PRESSURE	RELATED TEMPERATURE
PN 16	16 bar	50 °C
	14 bar	100 °C
	13 bar	195 °C
	12 bar	250 °C
CLASS 150	16 bar	50 °C
	13 bar	195 °C

* Rating according to EN 1092-1:2018.

CE MARKING – GROUP 2 (PED – European Directive)	
PN 16	Category
All sizes	4 (CE marked)

LIMITING CONDITIONS

Liquid specific gravity	0,8 to 1
Maximum viscosity	5 °Engler
Maximum motive inlet pressure	10 bar
Minimum motive inlet pressure	1 bar
Maximum operating temperature	185 °C
Minimum operating temperature *	20 °C
Pump discharge per cycle	325 L

* Lower limits on request.

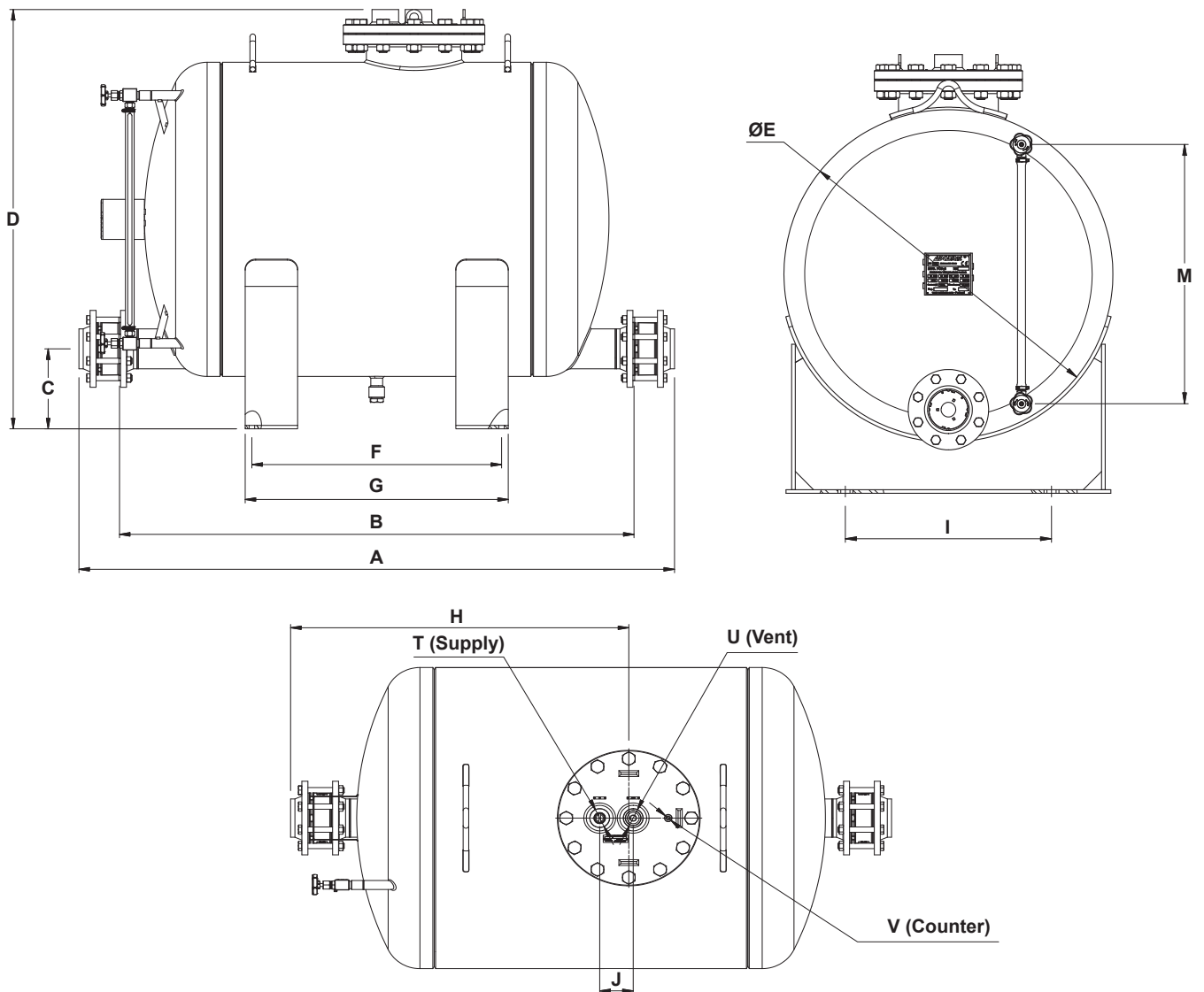

DIMENSIONS (mm)

SIZE	A *	B *	C	D	E	F	G	H	I	J	M	T **	U **	V **	WGT. (kg)	VOL. (L)
4" x 4" DN 100 x 100	1705	1473	229	1200	900	715	753	960	564	95	710	2"	2"	1/2"	565	1028

* With EN 1092-1 welding neck flanges. Dimensions may differ if ASME B16.5 flanges or ISO 7 Rp female threaded flanges are requested. Consult the manufacturer.

** As standard, in versions manufactured with EN 1092-1 PN 16 flanges, these connections are female threaded ISO 7 Rp. In versions with ASME B16.5 flanges, these connections are female threaded NPT.

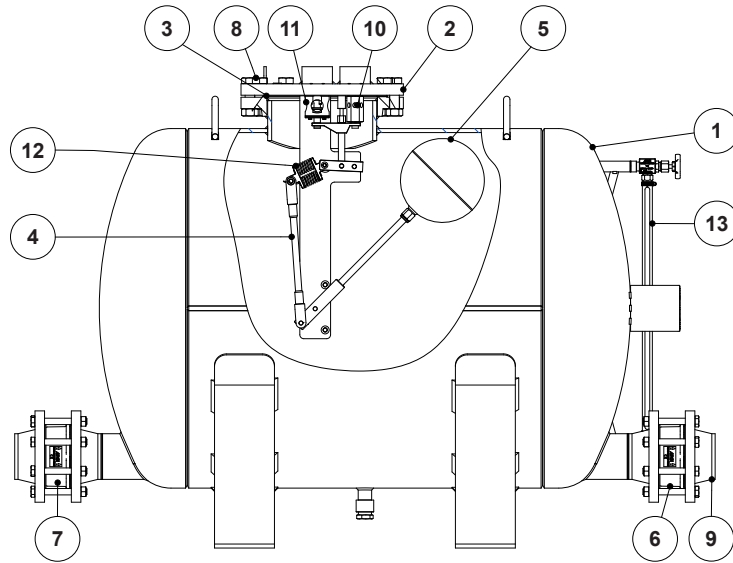

MATERIALS		
POS. N°	DESIGNATION	MATERIAL
1	Pump body	P265GH / 1.0425; P235GH / 1.0345; S235JR / 1.0038
2	Cover	GJS-400-15 / 0.7040
3	* Cover gasket	Stainless steel / Graphite
4	Internal mechanism	Stainless steel
5	* Float	Stainless steel
6	* Outlet check valve	A351 CF8M / 1.4408
7	* Inlet check valve	A351 CF8M / 1.4408
8	Bolts	Steel 8.8
9	Counter flanges	P250GH / 1.0460
10	* Intake valve/seat assembly	Stainless steel
11	* Exhaust valve/seat assembly	Stainless steel
12	* Springs	Inconel
13	** Level gauge cocks / Glass	See IS LGC400.10

* Available spare parts. ** Optional.

STROKE COUNTER

A stroke counter can be screwed onto a respective female threaded connection on the pump cover. Mechanical and digital versions are available. The mechanical version requires that the following conditions are met.

LIMITING CONDITIONS *	
Minimum motive pressure (steam)	6 bar
Minimum motive pressure (compressed air and nitrogen)	5 bar
Minimum system backpressure (steam)	700 mbar *
Minimum system backpressure (compressed air and nitrogen)	700 mbar *

* The pump outlet check valve can be supplied with a stronger spring to simulate increased system backpressure. Consult manufacturer.

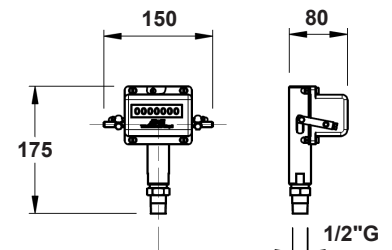

The digital version is composed of sensor and remote stroke counter. The device can be tailor made to meet customer requirements and is not dependent on the process condition. The standard unit is battery powered, features an LCD display and optional volt-free output connection for remote monitorization. Consult manufacturer.

SIZING

To accurately size a pressure operated pump, the following information must be provided:

1. The condensate load (kg/h).
2. The operating medium (steam, compressed air or other gases) and its pressure.
3. The total lift or backpressure in bar the pump will have to overcome. This includes the change in fluid level elevation after the pump (0.0981 bar/m of lift), plus pressure in the return piping, plus the pressure drop caused by pipe friction and other system components.
4. Available filling head (see Fig. 1) in mm or any other dimension that allows its determination.

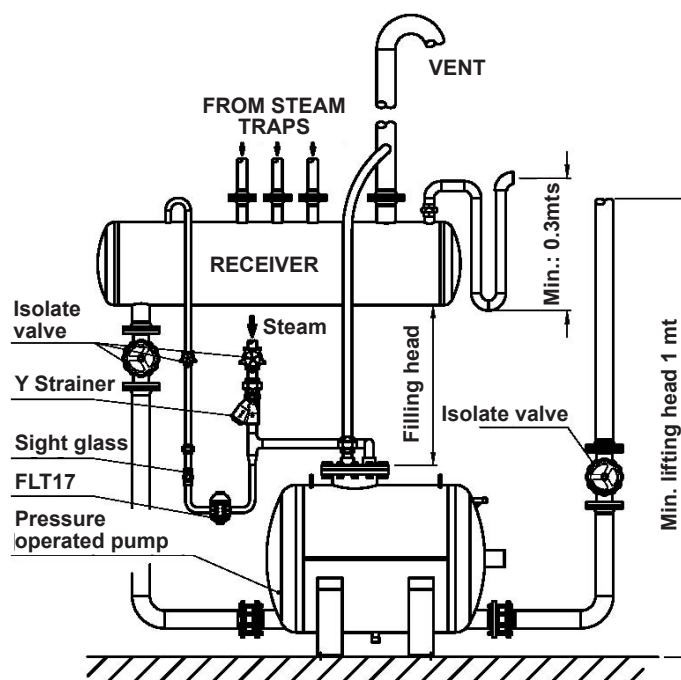

Fig. 1

CAPACITY CORRECTION FACTOR FOR GASES OTHER THAN STEAM					
% Backpress. vs Motive press. (BP/MP)	10%	30%	50%	70%	90%
Correction factor	1,04	1,08	1,12	1,18	1,28

Table 1

CAPACITY CORRECTION FACTORS FOR FILLING HEADS OTHER THAN 600 mm				
PUMP SIZE	FILLING HEAD (mm)			
	150	300	600	900
4" x 4" DN 100 x 100	0,7	0,8	1	1,08

Table 2

RECEIVER

A receiver is recommended to temporarily hold the liquid and prevent any flooding of the equipment, while the pump is performing a pumping cycle. A definable length of large diameter pipe can be used.

Suggested receiver sizes are shown in Table 3.

RECEIVER			
PUMP SIZE	4" x 4" DN 100 x 100		
	Pipe Ø x lenght	406 x 2000	640 x 1500

Table 3

FLOW RATE (kg/h) INSTALLATION WITH 600 mm FILLING HEAD ABOVE THE PUMP COVER		
MOTIVE PRESSURE (bar)	TOTAL LIFT (bar)	4" x 4" DN 100 x 100
1	0,35	13130
1,7		16850
3,5		21900
5		24830
7		26880
10		29800
1,7	1	16630
3,5		20400
5		23050
7		25100
10	29800	
2,5	1,5	13210
3,5		15150
5		17280
7		19100
10	21410	
3,5	3	11860
4		12300
5		12900
7		13740
10	14980	
4,5	4	11700
5		11840
7		12710
10	13760	

Table 4 (based on liquid specific gravity of 0,9 to 1,0)

Example

Condensate load	8500 kg/h
Filling head	150 mm
Motive fluid	Compressed air
Available pressure	7 bar
Vertical lift after pump	10 m
Return piping pressure	1,2 bar
Piping friction pressure drop	Negligible

Calculations:

Total back pressure: $1,2 \text{ bar} + (10 \text{ m} \times 0,0981) = 2,181 \text{ bar}$.

Assuming steam as motive medium at a pressure of 7 bar and a total backpressure of 3 bar, then according to Table 4 a DN 100 x 100 pump, with a capacity of 13740 kg/h, is the recommended size.

Correction for filling head:

With 150 mm filling head the correction factor from Table 2 is 0,7. The corrected capacity is thus $13740 \text{ kg/h} \times 0,7 = 9618 \text{ kg/h}$.

Correction for air as a motive fluid:

The % backpressure is $2,181 \text{ bar} / 7 \text{ bar} = 31\%$.

The correction factor from Table 1, is 1,08.

The corrected capacity is thus $9618 \text{ kg/h} \times 1,08 = 10387,44 \text{ kg/h}$, and so, a DN 100 x 100 pump is still the recommended size.