

SP10-47C

4 Way, 3 Position, Closed Center, 207 BAR Rated

A proportional solenoid-operated, four-way, three-position, spool-type, closed center, screw-in hydraulic cartridge valve.

Voltage	Hydraforce code	Article no.	Price £	Price €
CARTRIDGE VERSION				
24V DC	SP10-47C-0-N-24DG	SP1047CC24	£285.70	€342.80
INLINE WITH BODY 1/4" BSP				
24V DC	SP10-47C-2B-N-24DG	SP1047C2B24	£375.80	€451.00
INLINE WITH BODY 3/8" BSP				
24V DC	SP10-47C-3B-N-24DG	SP1047C3B24	£369.70	€443.60
with nitril seals				
WITH 'G' DIN CONNECTOR PLUG				

On request - Viton Seals - Screen filter protection - Manual Override
On request - For DC coils with spade or push on connections

Symbols

USASI:

ISO:

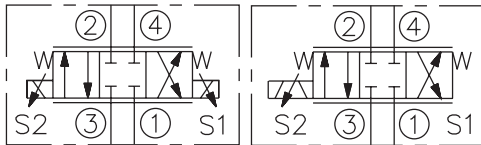

Dimensions

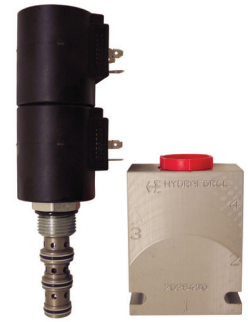
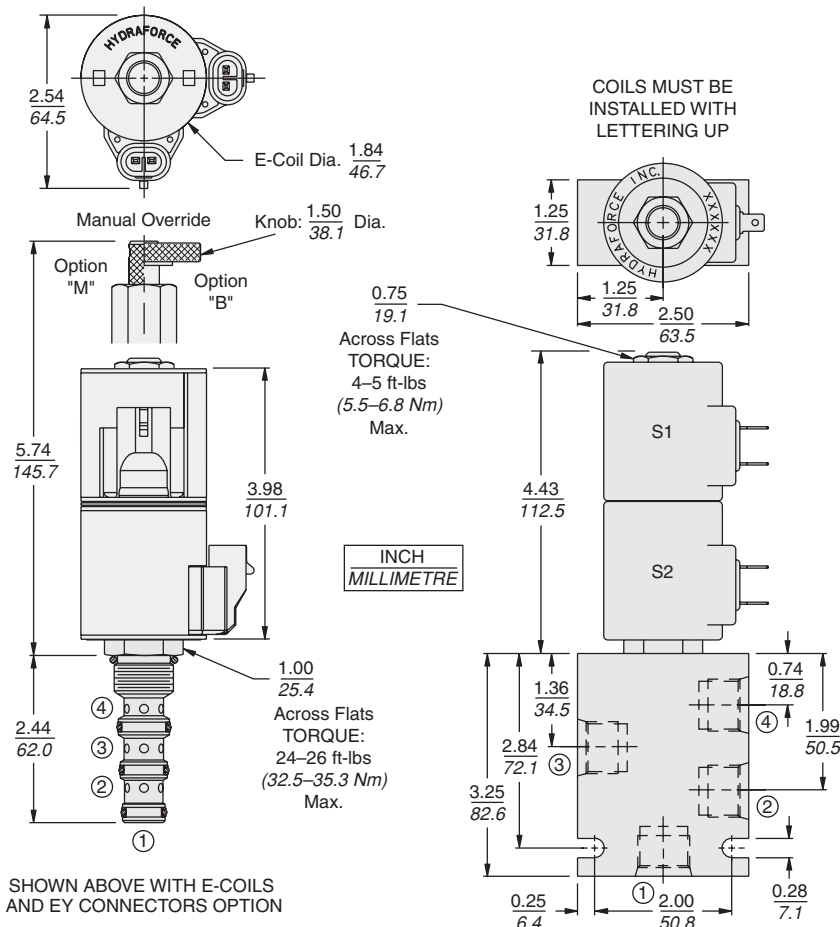

Materials

Cartridge:

Weight: 0.30 kg. (0.65 lbs.)
Steel with hardened work surfaces.
Zinc-plated exposed surfaces.
Buna N O-rings and back-ups std.

Standard Ported Body:

Weight: 0.36 kg. (0.80 lbs.)
Anodized highstrength 6061 T6 aluminum alloy, rated to 207 bar (3000 psi).
Ductile iron bodies available; dimensions may differ.

Standard Coil:

Weight each: 0.27 kg. (0.60 lbs.)
Unitized thermoplastic encapsulated.

Performance

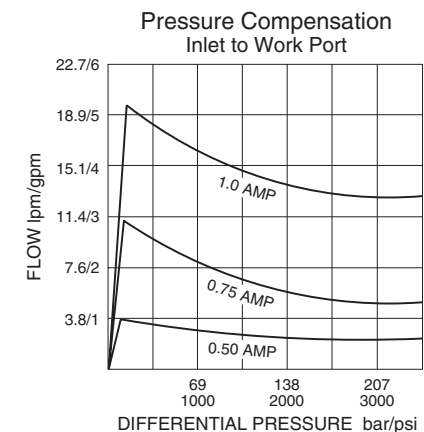
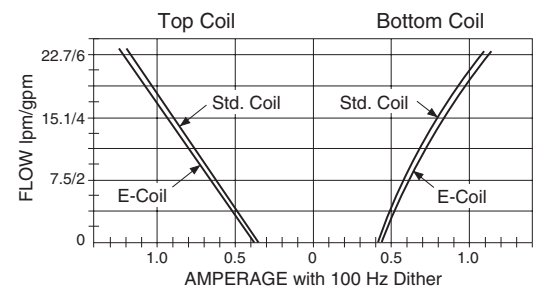
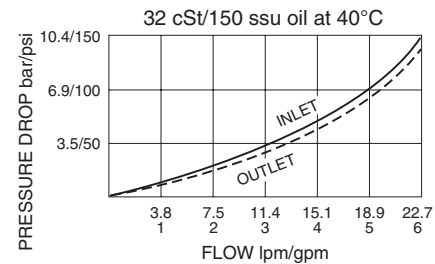

Please contact our technical sales team for electronic controller options