

SF08-22 HIGH PRESSURE

2 Way, Normally Closed, 345 BAR Rated

A solenoid-operated, 2-way, normally closed, piloted poppet-type, screw-in hydraulic cartridge valve, intended to act as a blocking or load-holding device for low flow circuits.



Voltage	Hydraforce code	Article no.	Price £	Price €
CARTRIDGE VERSION				
24V DC	SF08-22-0-P-24DG	SF0822C24	£136.90	€164.30
110V AC	SF08-22-0-P-115AG	SF0822C115	£161.90	€194.20
220V AC	SF08-22-0-P-230AG	SF0822C230	£169.30	€203.20
INLINE WITH DUCTILE IRON BODY 3/8" BSP				
24V DC	SF08-22-3BD-P-24DG	SF08223B24	£251.10	€301.40
110V AC	SF08-22-3BD-P-115AG	SF08223B115	£276.10	€331.30
220V AC	SF08-22-3BD-P-230AG	SF08223B230	£283.50	€340.20
with polyurethane seals				
WITH 'G' DIN CONNECTOR PLUG				

On request - Viton Seals - Screen filter protection - Manual Override
On request - For DC coils with spade or push on connections

Materials

Cartridge:

Weight: 0.09 kg. (0.20 lbs.)
Steel with hardened work surfaces.
Zinc-plated exposed surfaces.
Polyurethane cast O-rings and
Fluorocarbon back-up standard.

Ported Body:

Weight: 0.54 kg. (1.2 lbs.)
Ductile iron standard;
rated to 345 bar (5000 psi).

Standard Coil:

Weight: 0.11 kg. (0.25 lbs.)
Unitized thermoplastic encapsulated.

Dimensions

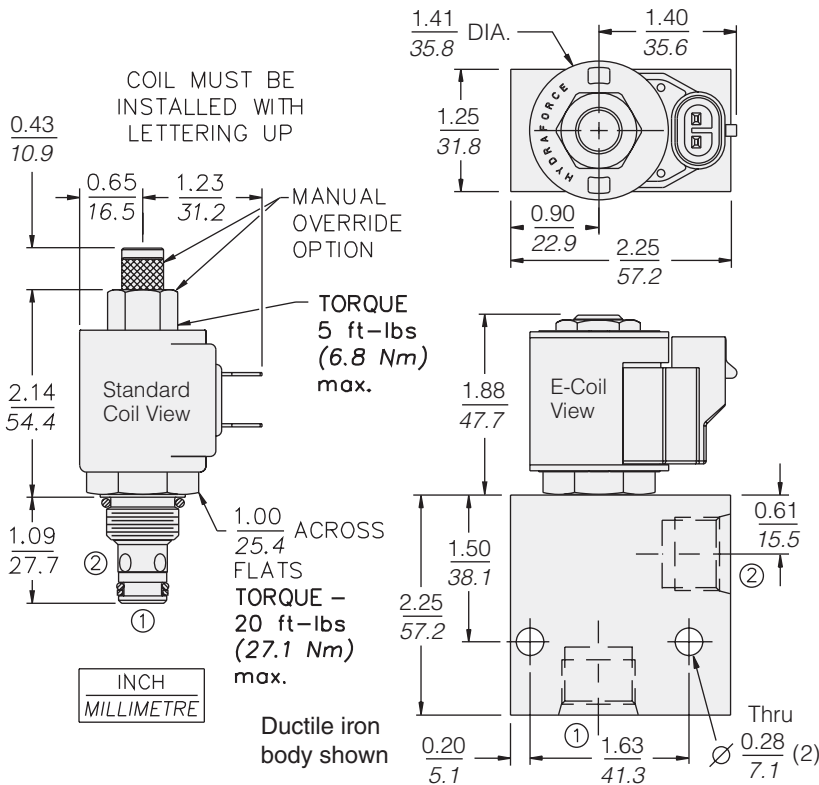

Symbols

USASI:

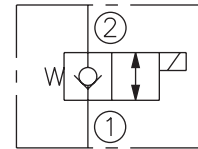

ISO:

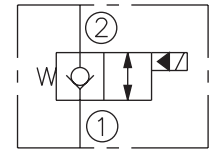

Performance (Cartridge Only)

