

# SF08-20 HIGH PRESSURE

2 Way, Normally Closed, 345 BAR Rated

A solenoid-operated, 2-way, normally closed, piloted poppet-type, screw-in hydraulic cartridge valve, intended to act as a blocking or load-holding device for low flow circuits.



Voltage	Hydraforce code	Article no.	Price £	Price €
<b>CARTRIDGE VERSION</b>				
24V DC	SF08-20-0-P-24DG	SF0820C24	£120.30	€144.40
110V AC	SF08-20-0-P-115AG	SF0820C115	£145.30	€174.30
220V AC	SF08-20-0-P-230AG	SF0820C230	£152.70	€183.20
<b>INLINE WITH DUCTILE IRON BODY 3/8" BSP</b>				
24V DC	SF08-20-3BD-P-24DG	SF08203B24	£234.50	€281.40
110V AC	SF08-20-3BD-P-115AG	SF08203B115	£259.50	€311.30
220V AC	SF08-20-3BD-P-230AG	SF08203B230	£266.90	€320.30
<b>with polyurethane seals WITH 'G' DIN CONNECTOR PLUG</b>				

On request - Viton Seals - Screen filter protection - Manual Override  
On request - For DC coils with spade or push on connections

## Materials

### Cartridge:

Weight: 0.09 kg. (0.20 lbs.).  
Steel with hardened work surfaces.  
Zinc-plated exposed surfaces.  
Polyurethane cast O-rings and  
Fluorocarbon back-up standard.

### Ported Body:

Weight: 0.54 kg. (1.2 lbs.).  
Ductile iron standard.  
Rated to 345 bar (5000 psi).

### Standard Coil:

Weight: 0.11 kg. (0.25 lbs.).  
Unitized thermoplastic encapsulated.

## Dimensions

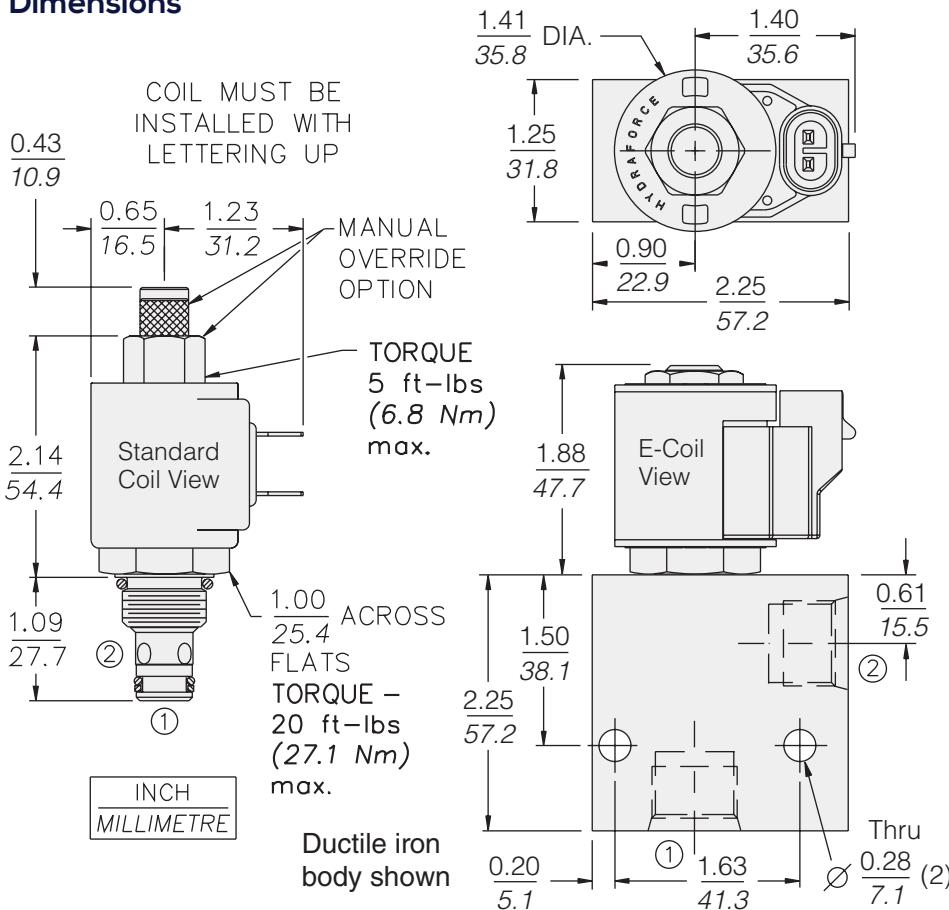

## Symbols

### USASI:

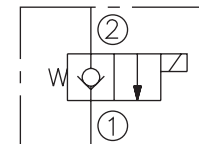

### ISO:

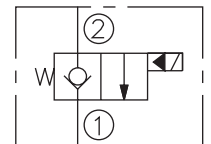

## Performance (Cartridge Only)

