

# SERIES 67 BALANCING VALVE

DN 40 - DN300

PN16 Flanged

The balancing valve Series 67 has a manual control handwheel with micrometric indicator, complete with fast plug pressure and flanged connection (EN 1092-2).

Article no.	Size	DN	Price £	Price €
MIV6708	1 1/2"	40	£411.40	€432.00
MIV6710	2"	50	£452.60	€475.20
MIV6712	2 1/2"	65	£737.50	€774.40
MIV6714	3"	80	£940.20	€987.20
MIV6718	4"	100	£1,298.30	€1,363.20
MIV6719	5"	125	£1,816.40	€1,907.20
MIV6720	6"	150	£2,279.60	€2,393.60
MIV6721	8"	200	£4,973.70	€5,222.40
MIV6722	10"	250	£7,297.50	€7,662.40
MIV6724	12"	300	£9,888.00	€10,382.40



**MIVAL**



GATE, GLOBE & BUTTERFLY VALVES

## Working Conditions

Temp Range -10°C to +120°C  
Max. Pressure 16 BAR

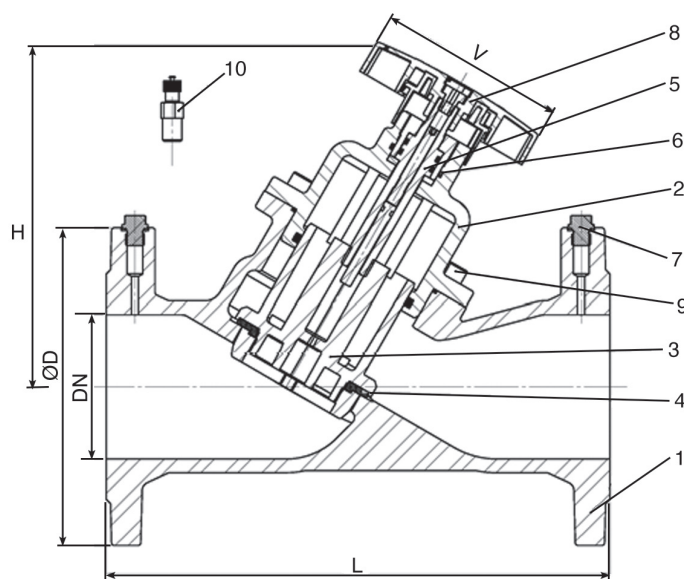

## Materials

1 Body	EN-GJL-250 Cast Iron
2 Bonnet (DN 40/50)	CW602N Brass
2 Bonnet (DN 65/150)	EN-GJL-250 Cast Iron
2 Bonnet (DN 200/300)	EN-GJS-500-7 Nodular Cast Iron
3 Disc	PPS
4 Disc Gasket	EPDM
5 Stem	CW602N Brass
6 O-Ring	EPDM
7 Plug G1/4"	CW602N Brass
8 Handwheel	Poliamid PA 6.6
9 Screw	8.8 Carbon Steel
10* Pressure tap G1/4"	CW602N Brass

\* Supplied separately

## Dimensions (mm)

DN	40	50	65	80	100	125	150	200	250	300
L	200	230	290	310	350	400	480	600	730	850
D	150	165	185	200	220	250	285	340	405	460
H	130	130	220	220	240	160	285	480	525	535
V	74	74	130	130	130	130	130	310	310	310
Kg	6.1	8.3	13.5	17.8	22.7	34	48.5	114.5	159	210.5

DN350/400 - Available on request