

# HQ-200 – HQ-300

## Specifications

Enclosure	Weatherproof IP67 (IP68 optional)
Power supply	110/220v 50/60Hz, 24vAC/DC, 380/440V 3 Phase
Duty cycle (On/Off Duty)	S4, 70% Standard, 100% for max 30 mins
Motor	Squirrel caged induction motor
Limit switches	4 x SPDT, 250V AC 10A
Torque switches	2 x SPDT, 250V AC 10A
Space heater	20W (110/220V AC) Anti condensation
Conduit entries	2 x M25 (PG13.5 or 1/2" NPT option)
Travel angle	90° ± 5°
Ambient temperature	-20°C to +70°C
External coating	Dry power, Polyester
Manual override	Handwheel with Declutch mechanism

## Option Specifications

Potentiometer Unit	1K – 10K
Proportional Control Unit	In/Out: 0-10V DC, 4-20mA
Current Position Transmitter	Output 4-20mA
Local Control Unit	Remote/Open/Stop/Close switch
Explosion Proof Enclosure	ATEX II 2G Eexd IIB T4
Fire Proof Actuator	250°C/150 min

## On Request

- With proportional control option
- With battery back-up for failsafe facility



Article no.	Mounting Details	Price £	Price €
HQ200	F16 36mm STAR	£4,265.60	€5,332.00
HQ300	F16 46mm STAR	£5,337.60	€6,672.00

Voltages suffix with  
 A = 240V  
 B = 110V  
 D = 24V

## Performance

Model	Torque Nm	Speed 90° 50/60Hz	Current (A) Max			Weight Kg	Max SQ. Drive
			110/1/50	220/1/50	380/3/50		
HQ-200	2000	112/93	4.10	2.30	0.85	75	55
HQ-300	3000	112/93	4.20	2.35	0.87	75	55

## Dimensions

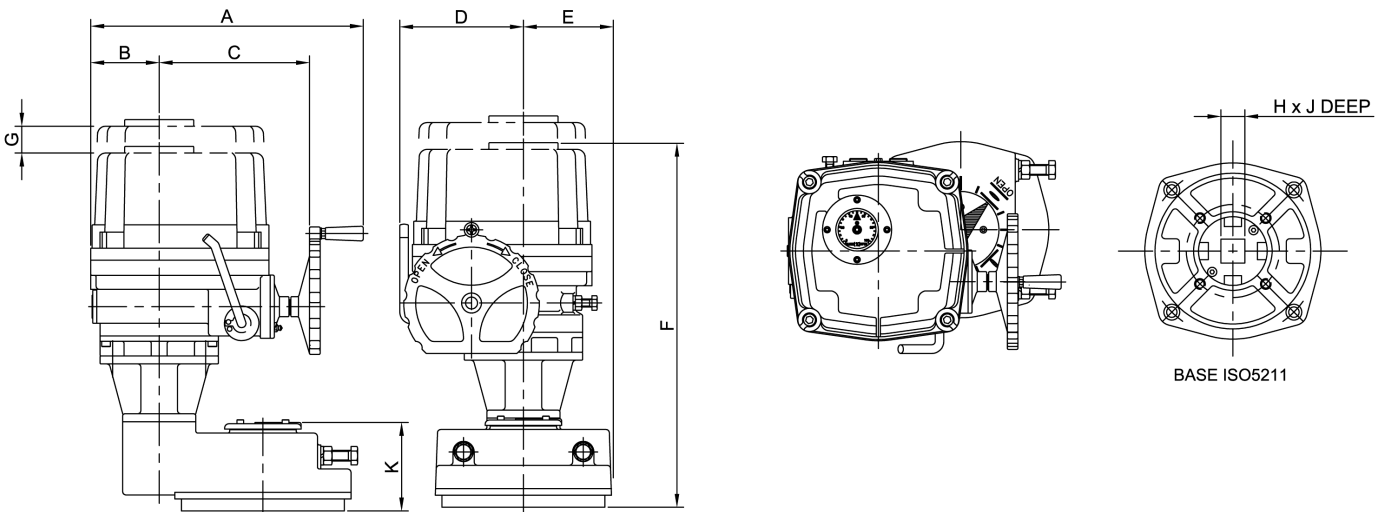

MODEL	BASE	A	B	C	D	E	F	G	H**	J
HQ200	F14*/F16	410	103	242	186	133	210	36	95	133
HQ300	F14*/F16	410	103	242	186	133	210	36	95	133

\* ON REQUEST \*\* CAN BE MACHINED TO SUIT MOST VALVE STEMS (ON REQUEST)