



CAST IRON & STAINLESS STEEL CONSTRUCTION GEARBOX

Features

- Sealed to IP67
- Maintenance free
- Self locking/High efficiency gears (for cast iron construction)
- High mechanical advantage
- Cast iron enclosure (for cast iron construction)
- Stroke: 0 - 90° (±5° adjustable)
- 50% Grease filled for life
- Capability to withstand overload to twice maximum output torque
- Rating -40°F to 176°F temperature range for continuous operation
- Versatility for direct mounting to valve
- Rugged construction
- Powder coated steel indicator (for cast iron construction)
- One piece stainless steel input shaft & worm

Options

- Padlockable Flange
- Limit switches
- Chainwheels
- Flexible extensions

Technical - Cast Iron & Stainless Steel

Ratio	Torque Nm (lbf/inch)		Handwheel Ø (mm/inch)	Weight kg
	Output	Input		
40.01.00	250 / 2200	22.7 / 200	125 / 511	2.7
42.01.00	500 / 4400	45 / 400	250 / 10	4.5
42.01.00	1000 / 8800	88 / 774	300 / 12	8.1
60.01.00	2200 / 19470	135 / 1194	450 / 18	14.5

Cast Iron

Article no.	ISO Size	Price £	Price €
WG200	F05 / F07	£104.00	€124.80
WG500	F07 / F10	£149.80	€179.70
WG1000	F10 / F12	£220.80	€265.00
WG2000	F14	£368.00	€441.60

Stainless Steel

Article no.	ISO Size	Price £	Price €
WG200SS	F07	£409.60	€491.50
WG500SS	F10	£801.80	€962.10
WG1000SS	F12	£1,296.00	€1,555.20
WG2000SS	F14	£2,042.60	€2,451.10

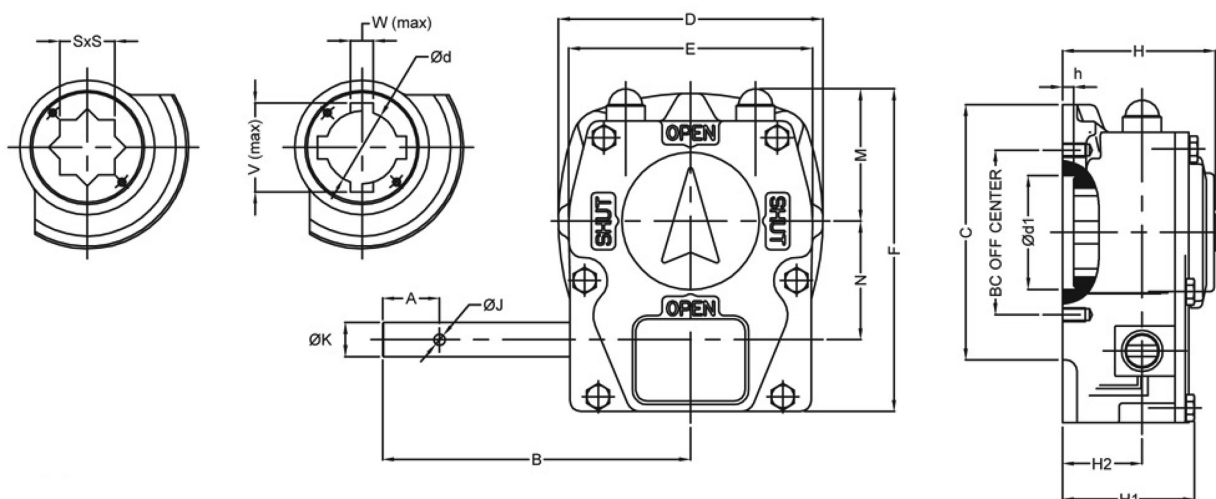

Dimensions (mm) - Cast Iron & Stainless Steel

Type	A	B	C	D	E	F	h	H	H1	J	K	M	N	d1	d	V	W	S	ISO5211
WG200	20	120	88	88	84	107	1	57	51	4	12	45	39	45	25	33.9	9.57	9/11/14	F05, F07
WG500	25	135	112	116	107	142	4.5	67	57	5	15	58	52	50	32	40.9	9.57	14/17/22	F07, F10
WG1000	32	168	147	150	136	157	5.2	81	73	6	20	74	67	65	45	55.2	11.17	22/27	F10/F12
WG2000	32	185	192	198	184	217	5.2	98	80	8	20	90	90	90	65	82.2	19.1	36	F14