

WORCESTER NEW SERIES 51 FLANGED BALL VALVE

Carbon Steel / Stainless Steel - PTFE Seat & Seals
ANSI 150

The proven Worcester 51/52 series flanged ball valve from Flowserve has been engineered for worldwide availability and shorter lead times by standardising its design, materials and construction. As a result, the 51/52 series valve minimises fugitive emissions, enhances safety, and ensures regulatory and standards compliance to help companies achieve decarbonization and sustainability objectives.



Locking wrench is standard on sizes through NPS 4 (DN100).

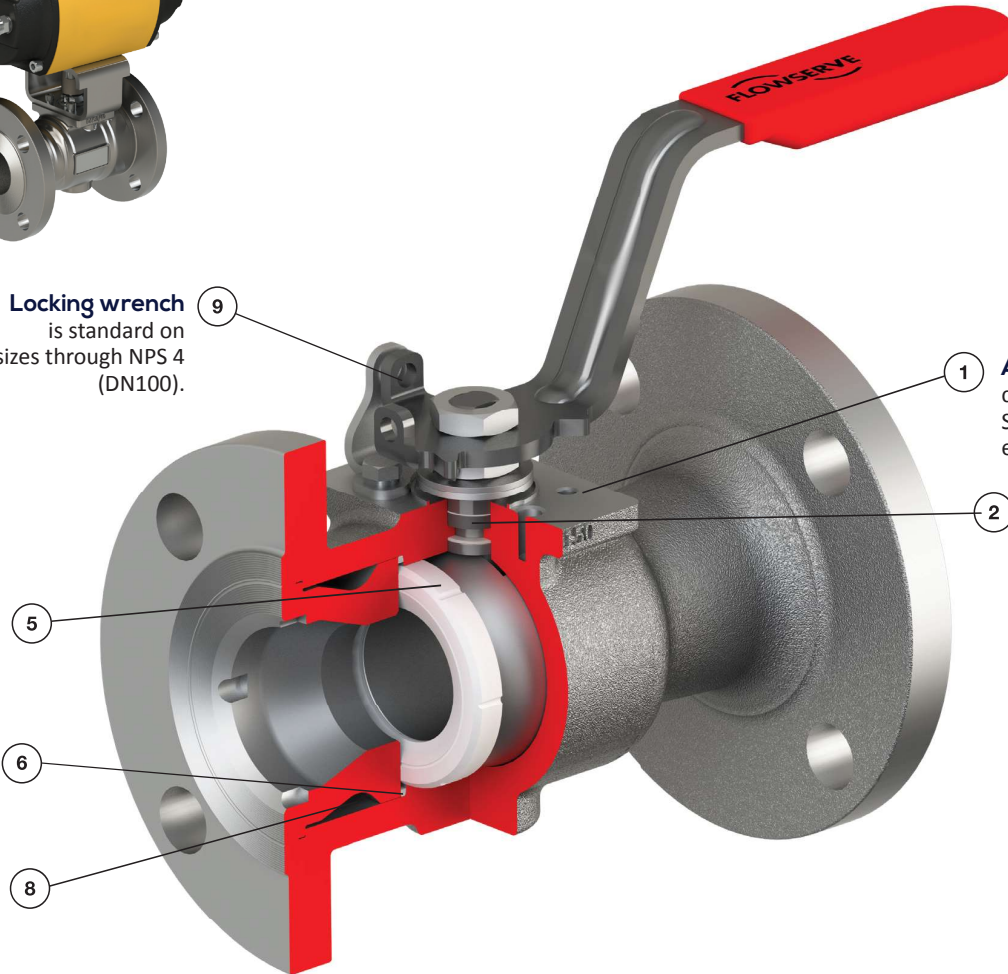

1 Actuator mounting conforms to ISO 5211 and Shell MES C SPE 77/300 for ease of actuation.

2 Standard anti-blowout, duplex stainless steel stem provides greater safety, increased maximum allowable stem torque (MAST) and excellent durability.

5 Seat design is available in a wide range of materials to meet specific application requirements; the cavity pressurerelevating (CPR) design ensures that pressure generated through media expansion when the valve is closed is safely relieved upstream.

6 Body seals are PTFE as 4 standard with fire-safe integrity maintained with metal-to-metal secondary sealing; compliant with API 607, API 608, API 641, ISO 17292 and ISO 15848.

8 Threaded insert provides leak-tight positive retention and improved customer safety.

3 Locking clip maintains position of the gland nut during actuation for long, leak-free performance; the gland nut does not need to be removed for actuator mounting, thereby maintaining valve integrity.

4 Live-loaded packing for enhanced reliability; conforms to API 641 and ISO 15848 fugitive emissions certification standards.

7 Anti-static design is standard.

WORCESTER NEW SERIES 51 FLANGED BALL VALVE

Carbon Steel / Stainless Steel - PTFE Seat & Seals
ANSI 150



FLOWSERVE

CARBON STEEL

Article no.	Size	Price £	Price €
453715	1/2"	£456.20	€547.40
453716	3/4"	£497.50	€597.00
453717	1"	£550.70	€660.80
453718	1 1/2"	£793.20	€951.90
453719	2"	£732.90	€879.50

STAINLESS STEEL

Article no.	Size	Price £	Price €
453710	1/2"	£716.80	€860.10
453711	3/4"	£726.90	€872.30
453712	1"	£1,017.60	€1,221.10
453713	1 1/2"	£1,313.40	€1,576.10
453714	2"	£1,220.20	€1,464.30

Dimensions

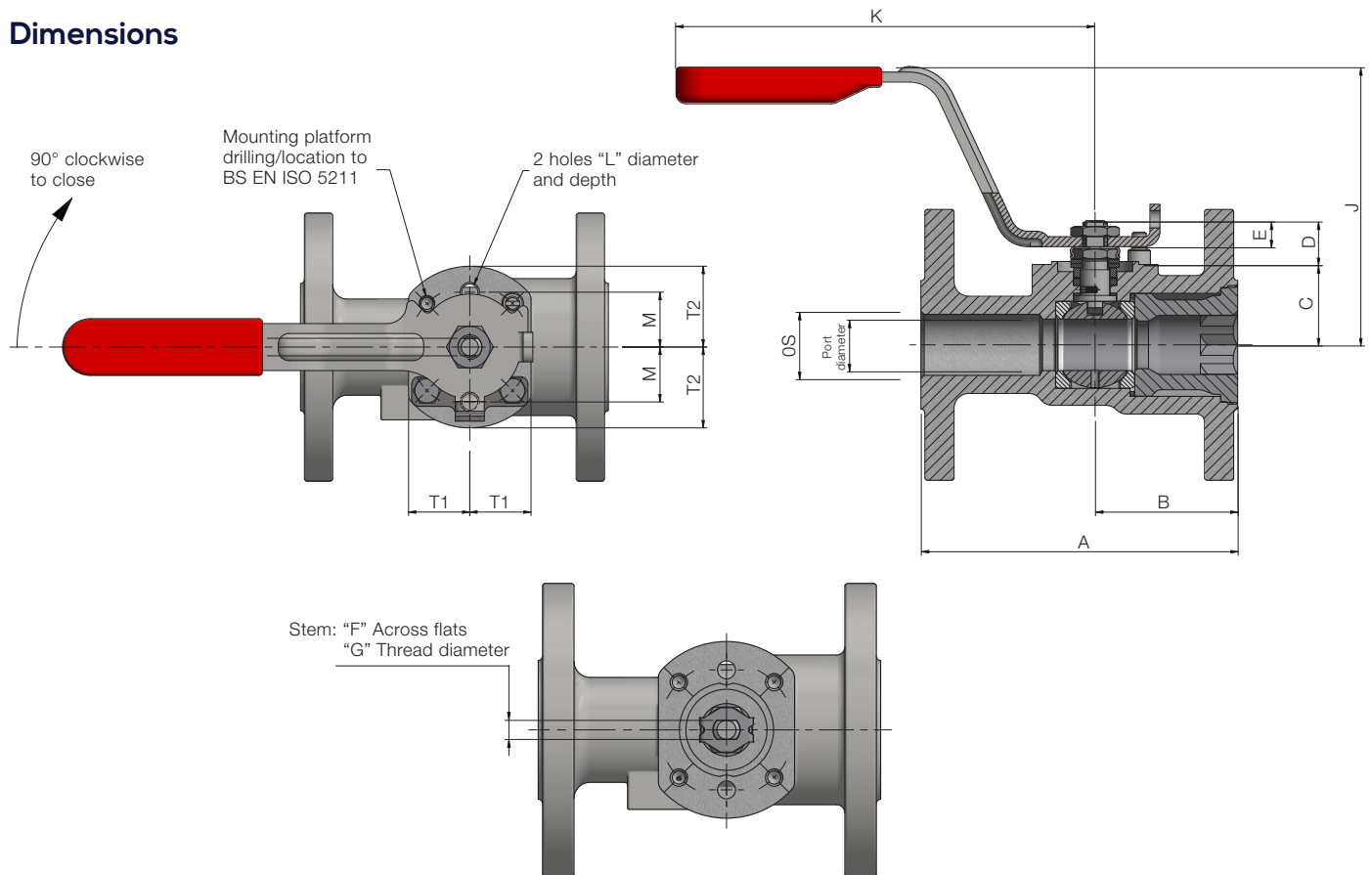

Valve Size DN	Valve Size NPS	Min. Port Ø	A	B	C ⁽¹⁾	D ⁽¹⁾	E Min.	Stem		J	K	L Thread & Depth	M	S Ø	T1	T2	ISO Size ⁽²⁾	Approx. Weight kg
								F ⁽¹⁾	G Thread									
15	1/2	11.1	108.0	52.5	22.96 22.70	18.0 17.0	8.1	7.00 6.96	M10 x 1.25p	102.6	155	M6 x 1.0p 9.2 MIN.	16.9	15	19.2	23.25	F03	1.8
20	3/4	14.4	117.0	54.6	22.96 22.70	18.0 17.0	8.1	7.00 6.96	M10 x 1.25p	102.6	155	M6 x 1.0p 9.5 MIN.	16.9	20	19.2	23.25	F03	2.2
25	1	20.7	127.0	57.2	32.34 32.08	18.0 17.0	10.4	7.00 6.96	M10 x 1.25p	111.6	168	M8 x 1.25p 9.7 MIN.	22.25	27	25.25	32.8	F05	3.1
40	31.3	31.8	165.0	66.6	42.33 42.07	27.0 26.0	11.8	9.50 9.46	M14 x 1.25p	130.9	193	M8 x 1.25p 9.7 MIN.	22.25	40	25.25	32.8	F05	5.6
50	37.7	38.2	178.0	70.9	47.06 46.80	27.0 26.0	11.8	9.50 9.46	M14 x 1.25p	135.7	193	M8 x 1.25p 9.7 MIN.	22.25	50	27	38.75	F05	8.0