

FD50-45

Flow Divider/cominer, Heavy Duty, Multifunction, 5,000 PSI Rated

A heavy duty, multifunction, screw-in, cartridge-style, spool-type flow divider/cominer.

Porting	Hydraforce code	Article no.	Dividing/Combining Ratio	Price £	Price €
Cartridge Version	FD50-45-0-P-*	FD50450C*	* suffix with 22 = 50:50 rated / 15.1 lpm input 33 = 50:50 rated / 22.7 lpm input	£108.50	€130.20
INLINE 3/8" BSP	FD50-45-3BD-P*	FD50453B*	44 = 50:50 rated / 34.1 lpm input 66 = 50:50 rated / 45.4 lpm input	£364.00	€436.80

with polyurethane seals

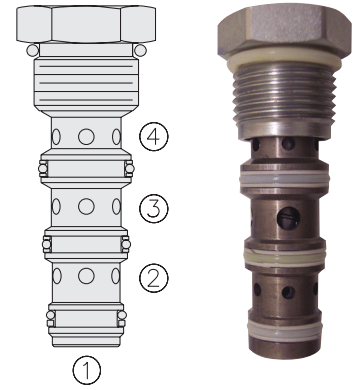

Materials

Cartridge:

Weight: 0.10 kg. (0.23 lbs.)
Steel with hardened work surfaces.
Zinc-plated exposed surfaces.
Buna N O-rings and polyester elastomer back-ups standard.

Special Ported Body:

Ductile iron, required for operation over 207 bar (3000 psi). Aluminum bodies are available for lower pressure operation.

Dimensions



Installation Torque:
48-52 ft-lbs (65-71 Nm)

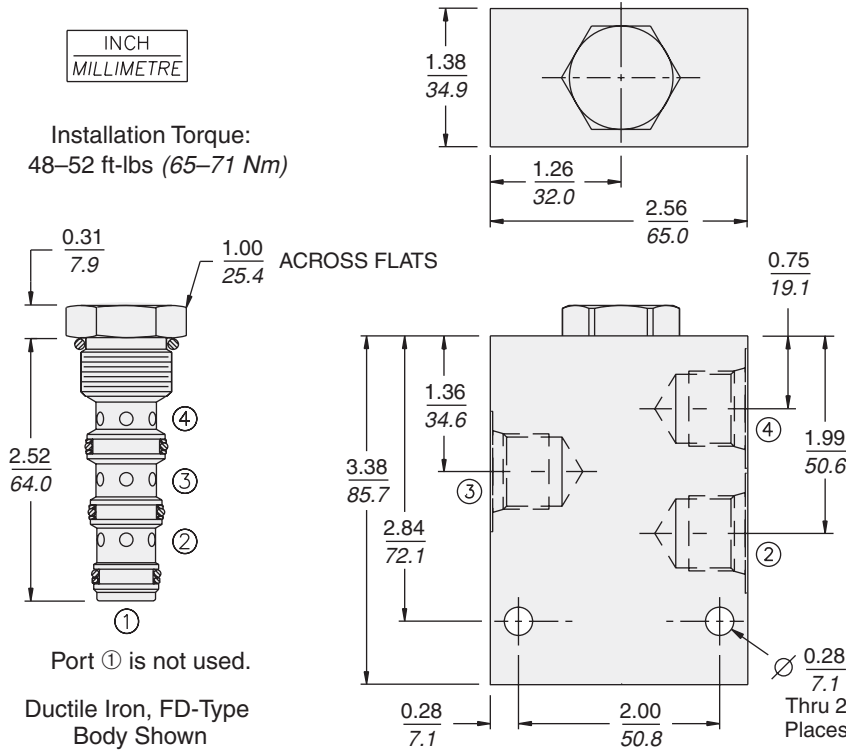

Symbols

USASI:

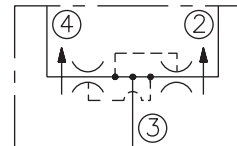

ISO:

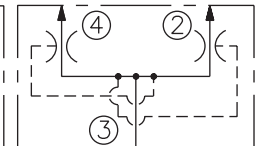

Performance

Pressure Drop vs. Inlet Flow
③ to ② and ④
32 cSt/150 ssu oil at 40°C

