

EC10-40

Pressure Compensator 207 BAR Rated

A screw-in, cartridge-style pressure-compensating element, intended for use with a remote fixed or variable orifice to yield a three-port (bypass-type), pressure compensated, flow regulating hydraulic valve.

Operation

The EC10-40 maintains a constant flow rate from ③ regardless of load pressure changes in the circuit downstream of ③.

The cartridge maintains a constant differential pressure from circuit point P to port ③, thereby regulating the hydraulic flow rate between the two points in the circuit. The EC10-40 is a priority type regulator, delivering pump flow first to ③, then bypassing excess to ②. All ports may be fully pressurised.

Porting	Hydraforce code	Article no.	Spring Options	Price £	Price €
Cartridge Version	EC10-40-0-N-*	EC10400C*	* suffix with	£77.00	€92.40
INLINE 1/4" BSP	EC10-40-2B-N*	EC10402B*	40 = 2.8 BAR (40 PSI) 80 = 5.52 BAR (80 PSI) 160 = 11 BAR (160 PSI)	£167.10	€200.60
INLINE 3/8" BSP	EC10-40-3B-N*	EC10403B*		£161.00	€193.20

with nitril seals / Viton on request

Dimensions

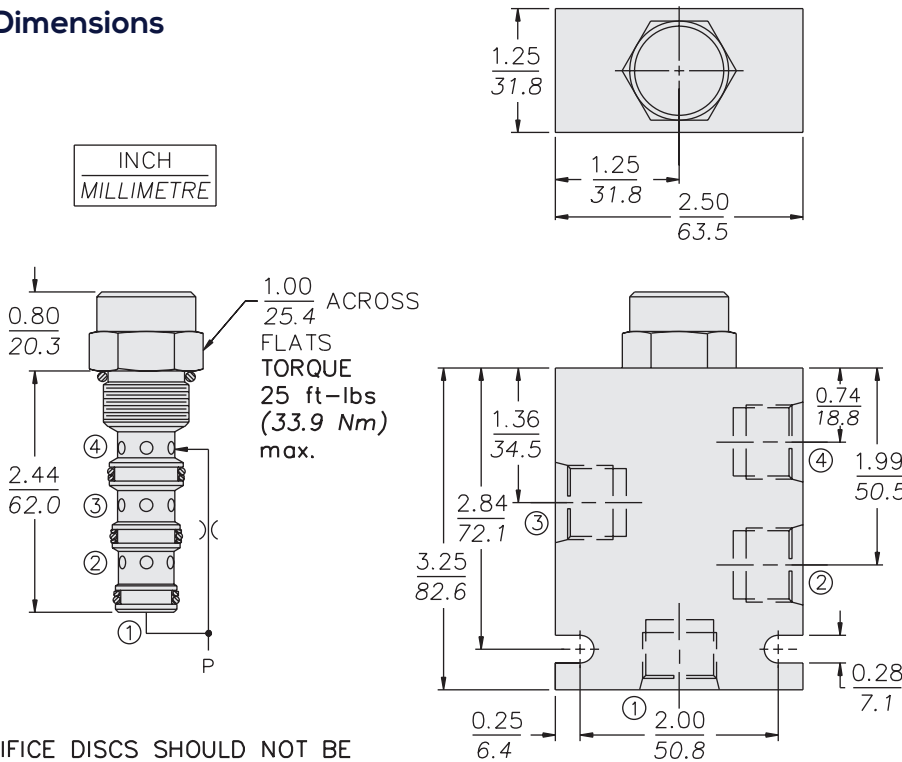

ORIFICE DISCS SHOULD NOT BE USED WITH THIS PRODUCT.

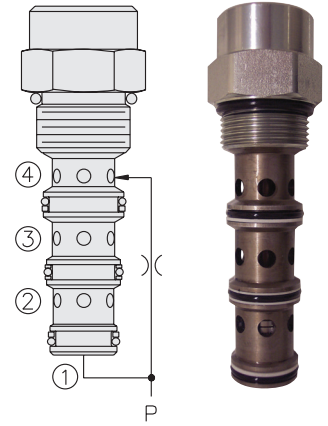

Materials

Cartridge:

Weight: 0.16 kg. (0.35 lbs.)
Steel with hardened work surfaces.
Zinc-plated exposed surfaces.
Buna N O-rings and polyester elastomer back-ups standard.

Standard Ported Body:

Weight: 0.34 kg. (0.75 lbs.)
Anodized highstrength 6061 T6 aluminum alloy, rated to 207 bar (3000 psi).
Ductile iron bodies available; dimensions may differ.

Symbols

USASI/ISO:

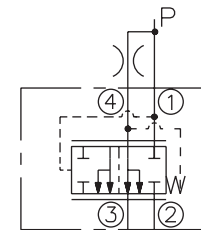

Performance

Output Flow vs. Orifice Dia.
with 80 psid Spring
32 cSt/150 ssu oil at 40°C

