



# WCB CAST STEEL GLOBE VALVE

**ANSI 150**

**Handwheel Operated**



Article no.	Size	DN	Price £	Price €
562744	2"	40	£601.70	€722.10
562745	3"	50	£890.40	€1,068.50
562746	4"	65	£1,238.30	€1,485.90
562747	6"	80	£2,167.00	€2,600.30

## Technical Data

Basic design	API 623
Face to face	ASME B16.10
Flange ends dimension	ASME B16.5
Test & inspection	API 598
Test duration time	API 6D
Nace	MR-0175
Design temperature	-29 to 427°C
Painting system	Manufacturers standard GMS TP 102.02 002

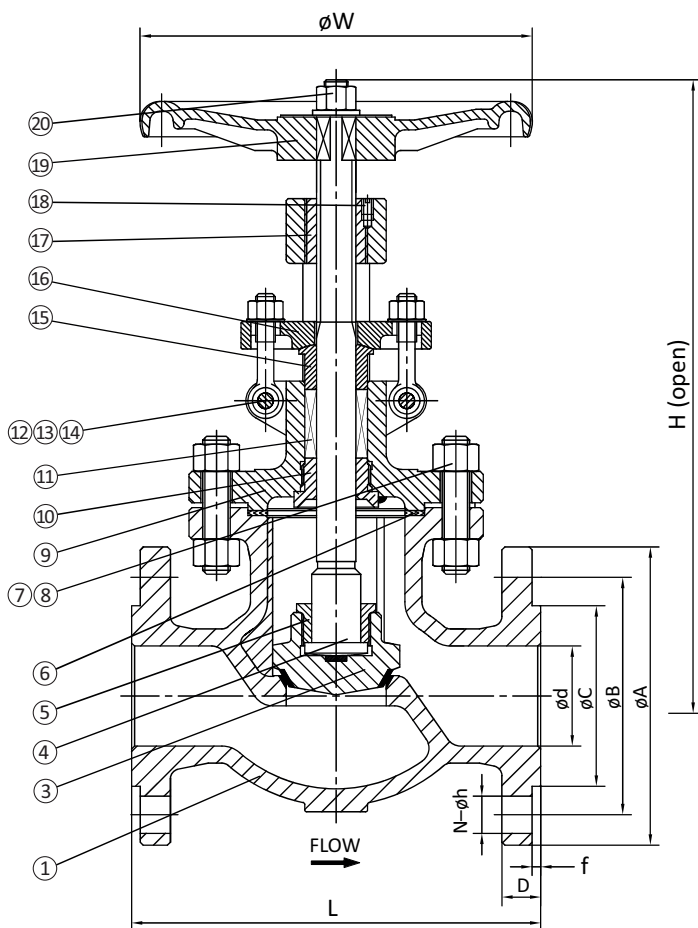

## Materials

1	Body	ASTM A216 WCB
3	Disc (2" - 3")	ASTM A182 F6A
3	Disc (4" - 6")	ASTM A105N+13Cr
4	Stem	ASTM A182 F6A
5	Disc nut	AISI 1035
6	Gasket	316SS + flexible graphite
7	Bolt	ASTM A193 B7
8	Nut	ASTM A194 2H
9	Bonnet	ASTM A216 WBC
10	Backseat	ASTM A182 F6A
11	Packing	Flexible graphite
12	Bolt	ASTM A193 B7
13	Nut	ASTM A194 2H
14	Pin	AISI 1035
15	Packing gland	ASTM A182 F6A
16	Gland flange	ASTM A105N
17	Stem nut	Copper alloy
18	Screw	AISI 1035
19	Handwheel	Ductile iron
20	Handwheel nut	ASTM A194 2H
* Seat integral with body & stellite overlay		

## Dimensions (mm)

Size	Ød	L	H	ØW	FLANGE							Weight Kg
					ØA	ØB	ØC	D	f	N	Øh	
2"	51	203	335	200	150	120.7	92.1	16.3	2	4	19	16
3"	76	241	415	250	190	152.4	127	19.5	2	4	19	28
4"	102	292	450	300	230	190.5	157.2	24.3	2	8	19	47
6"	152	406	551	400	280	241.3	215.9	25.9	2	8	22	80