



WCB CAST STEEL GATE VALVE

ANSI 150

Gearbox Operated - 14" to 24"

	Article no.	Size	Price £	Price €
Gearbox Operated	562756	14"	£8,556.50	€10,267.80
	562757	16"	£10,855.70	€13,026.80
	562758	18"	£13,805.20	€16,566.30
	562759	20"	£16,949.60	€20,339.50
	562760	24"	£23,725.20	€28,470.30

Technical Data

Basic design	API 600
Face to face	ASME B16.10
Flange ends dimension	ASME B16.10
Test & inspection	API 598
Test duration time	API 6D
Nace	MR-0175
Design temperature	-29 to 427°C
Painting system	Manufacturers standard GMS TP 102.02 002

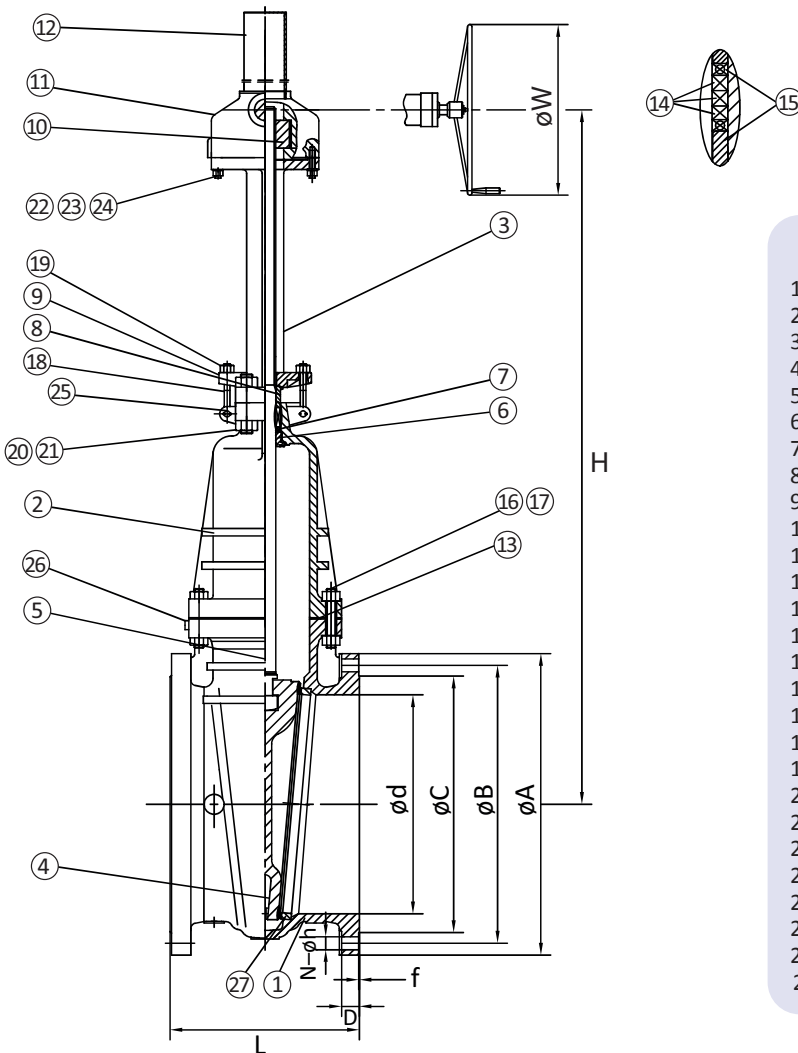

Materials

1	Body	ASTM A216 WCB
2	Bonnet	ASTM A216 WCB
3	Yoke	ASTM A216 WCB
4	Disc	ASTM A216 WCB+Stellite
5	Stem	ASTM A182 F6A
6	Backseat	ASTM A276 420
7	Packing ring	ASTM A276 420
8	Packing gland	ASTM A276 420
9	Gland Flange	ASTM A216 WCB
10	Stem nut	ASTM A439 D-2C
11	Gearbox	ASTM A216 WCB
12	Dustproof cover	ASTM A36
13	Gasket	304ss + flexible graphite
14	Packaging	Inconel wire + braided graphite
15	Packaging	Inconel wire + braided graphite
16	Bolt	ASTM A193 B7
17	Nut	ASTM A194 2H
18	Eyebolt	ASTM A193 B7
19	Nut	ASTM A194 2H
20	Bolt	ASTM A193 B7
21	Nut	ASTM A194 2H
22	Bolt	ASTM A193 B7
23	Nut	ASTM A194 2H
24	Spring washer	ASTM A1566
25	Pin	ASTM A1035
26	Nameplate	Stainless Steel
27	Seat	ASTM A105N+Stellite

Dimensions (mm)

Size	Ød	L	H	ØW	FLANGE							Weight Kg
					ØA	ØB	ØC	D	f	N	Øh	
14"	337	381	1134	305	535	476.3	412.8	35.4	2	12	29	390
16"	387	406	1288	305	595	539.8	469.9	37	2	16	29	525
18"	438	432	1444	305	635	577.9	533.4	40.1	2	16	32	856
20"	489	457	1587	458	700	635.0	584.2	43.3	2	20	32	956
24"	591	508	1870	458	815	749.3	692.2	48.1	2	20	35	1416