

# CV16-20

## Check Valve 207 BAR Rated

A screw-in, cartridge-style, hydraulic check valve for use as a blocking or load-holding device.

Porting	Hydraforce code	Article no.	Spring Options	Price £	Price €
Cartridge Version	CV16-20-0-N-*	CV1620C*	* suffix with	£66.10	€79.30
INLINE 3/4" BSP	CV16-20-6B-N-*	CV16206B*	5 = 0.35 BAR (5 PSI) 25 = 1.7 BAR (20 PSI) 60 = 4.1 BAR (60 PSI)	£165.90	€199.10
INLINE 1" BSP	CV16-20-8B-N-*	CV16208B*		£165.90	€199.10

with nitril seals / Viton on request

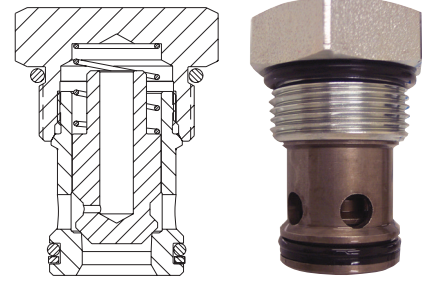

### Materials

#### Cartridge:

Weight: 0.29 kg. (0.63 lbs.)  
Steel with hardened work surfaces.  
Zinc-plated exposed surfaces.  
Buna N O-rings and polyester elastomer back-ups standard.

#### Standard Ported Body:

Weight: 0.57 kg. (1.25 lbs.)  
Anodized highstrength 6061 T6 aluminum alloy, rated to 207 bar (3000 psi).  
Ductile iron bodies available; dimensions may differ.

### Dimensions

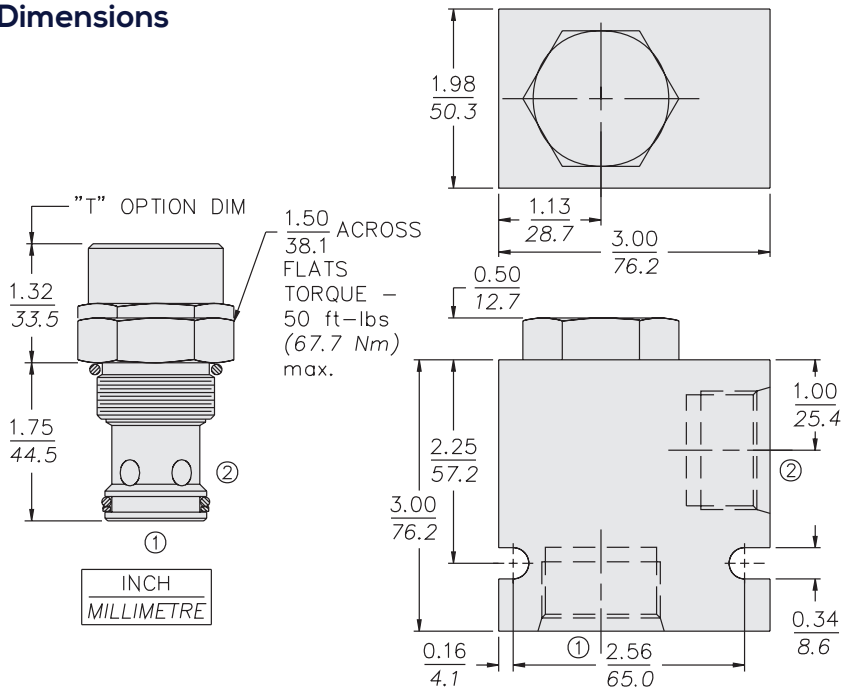

### Symbols

#### USASI:

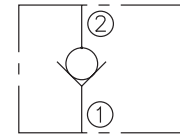

#### ISO:

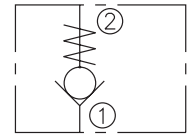

### Performance

① to ②: 0.34 bar/5 psi spring — ;  
1.72 bar/25 psi spring - - -  
32 cSt/150 ssu oil at 40°C

