

Safety valves



THREADED SAFETY VALVES	56
FLANGED SAFETY VALVES	57

■ THREADED VALVES can be manufactured according to the following standards:

ANSI - ASME B1.20.1 - NPT
GAS UNI - ISO228
ISO7/1 RC - RP THREADS

■ FLANGED VALVES can be manufactured according to the following standards:

PN16
PN20
B16.24 ASA 150

■ Special SEALING MATERIALS are available upon request:

TEFLON
NBR
EPDM



VS190001

BRASS SAFETY VALVE TOP OUTLET PN16 M SCREWED ENDS PN16

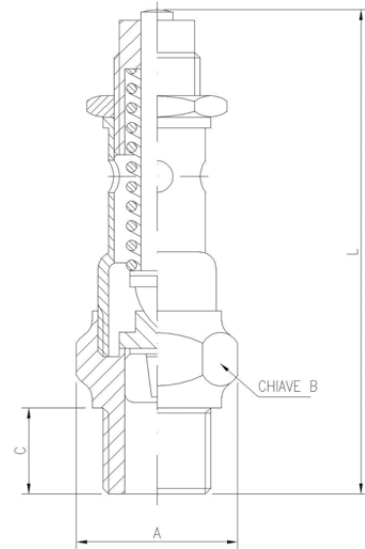

STANDARD MATERIALS

Body	BRASS-CW617N UNI EN12165
Disc	BRASS-CW617N UNI EN12165
Stem	BRASS-CW614N UNI EN12164
Seat	BRASS-CW617N UNI EN12165

	1-4"	3-8"	1-2"	3-4"	1"	1"1-4	1"1-2	2"
L (mm)	89	89	89	116,5	129	148,5	153	179
A (mm)	30	30	30	43,5	53	68,5	74,5	89
B (mm)	26	26	26	40	49	63	69	82
C (mm)	11,5	11,5	11,5	16	18	23	24,5	25,5



VS190604

BRASS ANGLE SAFETY VALVE SIDE OUTLET PN16 FXF SCREWED ENDS PN16

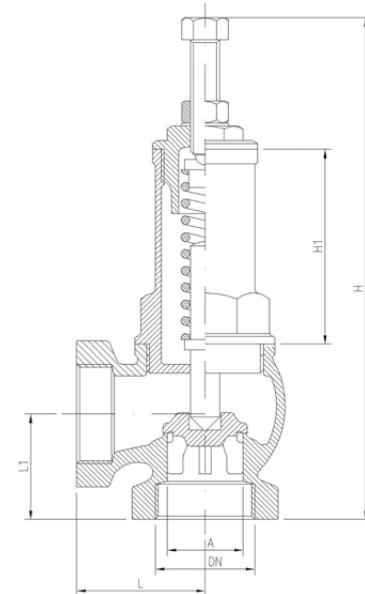

STANDARD MATERIALS

Body	BRASS-CW617N UNI EN12165
Bonnet	BRASS-CW617N UNI EN12165
Disc	BRASS-CW617N UNI EN12165
Stem	BRASS-CW614N UNI EN12164
Seat	INTEGRAL SEAT

	3-8"	1-2"	3-4"	1"	1"1-4	1"1-2	2"	2"1-2	3"
H (mm)	118	125	149	165	195	212	238	305	335
H1 (mm)	45	45	56	63	78	87	92	100	113
L (mm)	26	34	40	45	54	60	72	87	87,5
L1 (mm)	23,5	28,5	31,5	40	42,5	47	60	74,5	84
A (mm)	10	13	19	25,5	31	38	48	63,5	77

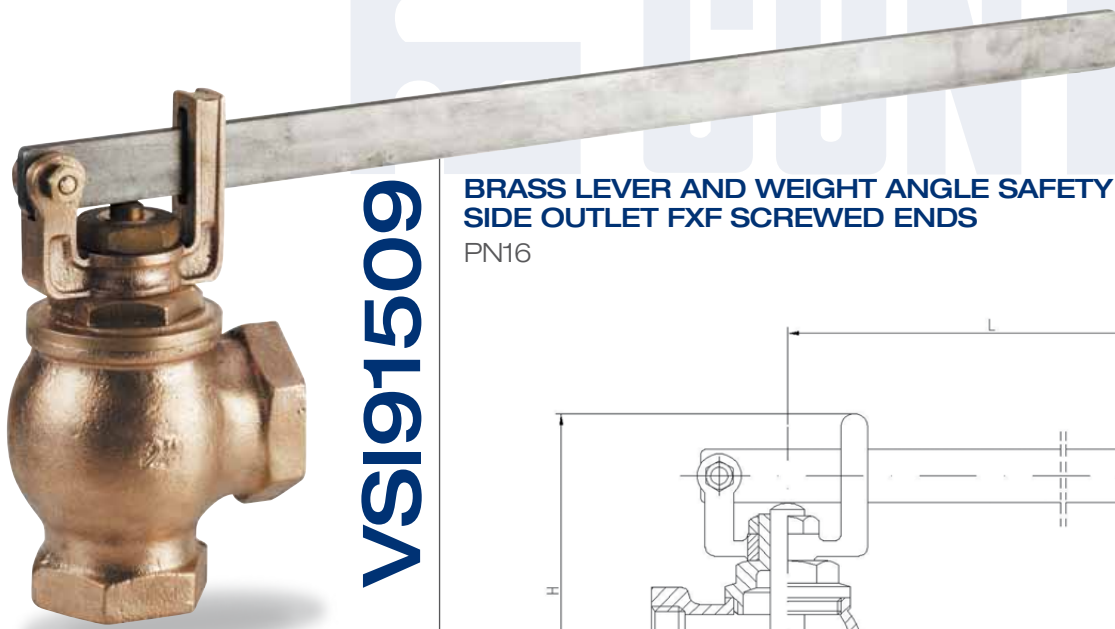

VS191509

**BRASS LEVER AND WEIGHT ANGLE SAFETY VALVE PN16
SIDE OUTLET FXF SCREWED ENDS**

PN16

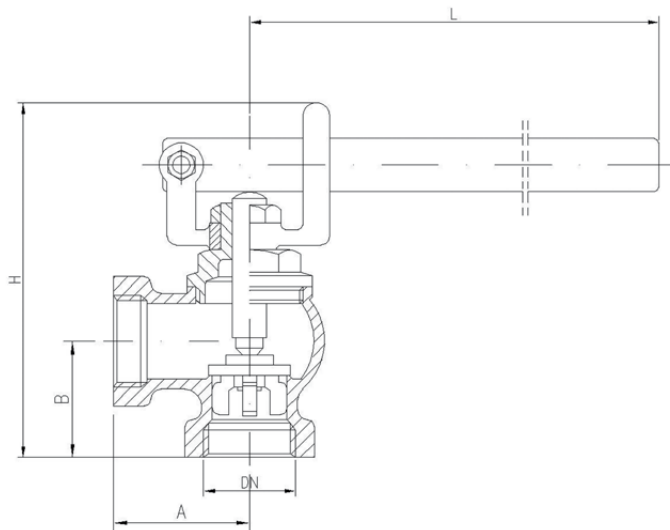

STANDARD MATERIALS

Body	BRASS-CW617N UNI EN12165
Bonnet	BRASS-CW617N UNI EN12165
Disc	BRASS-CW617N UNI EN12165
Stem	BRASS-CW614N UNI EN12164
Seat	INTEGRAL SEAT

	2"
A (mm)	74
B (mm)	57
L (mm)	560
H (mm)	196



VS190500

**BRONZE STRAIGHT SAFETY VALVE PN16
METAL SEAT FLANGED ENDS**

PN16

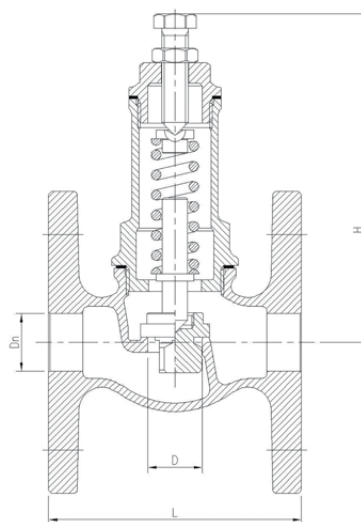

STANDARD MATERIALS

Body	BRONZE CC491K UNI EN1982
Bonnet	BRASS-CW617N UNI EN12165
Disc	BRASS-CW614N UNI EN12164
Stem	BRASS-CW614N UNI EN12164
Seat	INTEGRAL SEAT

	015	020	025	032	040	050	065	080	100
D (mm)	15	19	24,5	31,5	38	48	64	75	96
L (mm)	70	90	99	108	130	147	190	207	220
H (mm)	93	120	137	163	172	192	228	235	297