

# L182 SERIES SOLENOID VALVE

2/2 Normally Closed - Pilot Operated - G 3/8-G1

## General Features

Diaphragm valve, pilot operated, having full orifice.

Suitable to shut off liquid and gaseous fluids (verify the compatibility of fluid with material in contact).



## Technical Features

Maximum allowable pressure (PS)	20 bar			
Response times	<b>3/8</b>	<b>1/2</b>	<b>3/4</b>	<b>1</b>
Opening time (ms)	70	70	70	90
Closing time (ms)	670	600	500	420
Fluid temperature	-10°C +90°C (NBR) 0°C +130°C (FPM) -10°C +140°C (EPDM)			
Max viscosity	5°E (~37 cStokes or mm <sup>2</sup> /s)			
<b>Coil</b>	<b>ZB10A</b>			
Power consumption	12/6VA - 5.5W			
Encapsulation material	PA fiberglass reinforced			
Insulation class	F (155°C)			
Ambient temperature	-10°C +60°C			
Continuous duty	ED 100%			
Electric connection	DIN 46340 - 3 poles plug connector			
Protection degree	IP 65 (EN 60529) with plug connector			
	DC 12-24V (+10% -5%)			
Voltages	AC 24V/50-60Hz - 115V/50Hz - 230V/50-60Hz (+10% -15%) (Other voltages and frequencies on request)			

## Materials - in contact with fluid

Body	Brass
Sealing	NBR FPM or EPDM on request
Internal components	Brass and stainless steel
Seat	Brass
Core tube	Stainless steel
Shading coil	Copper

Article no.	Size	Orifice	KV (m <sup>3</sup> /hr)	Differential Pressure (bar)		Price £	Price €
				Δ p min	Δ p max		
453394*	G3/8"	13.5	2.5	0.35	16	<b>£98.70</b>	<b>£118.50</b>
453395*	G1/2"	13.5	3.8	0.35	16	<b>£103.50</b>	<b>£124.20</b>
453396*	G3/4"	18	5	0.35	12	<b>£136.40</b>	<b>£163.70</b>
453397*	G1"	24	12	0.35	12	<b>£207.10</b>	<b>£248.50</b>

## Dimensions (mm)

D	a	b	c	f	g	l	s
G 3/8	60	66	77	40	25.5	20	22
G 1/2	66	68	82	40	29	20	27
G 3/4	79	72.5	89	50	35.5	24.5	33
G 1	105	85	106	71	46	28	42

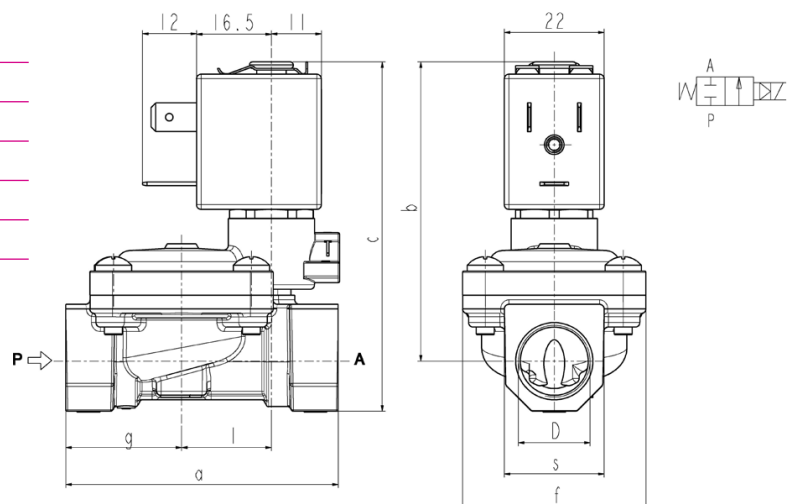

## Notes

- Operation with gaseous media, at high pressure without any outlet restriction, can reduce the diaphragm life.
- On request coil in class H (ZB14A – see § "COIL" )
- 1 - Low power consumption coil on request (3,5 VA in AC – 3W in DC): Δp max = 12 bar
- 2 - Low power consumption coil on request (3,5 VA in AC – 3W in DC): Δp max = 8 bar
- 3 - L182D01 – L182D02: Product under recertification process WRAS.