

MULTIWAY BALL VALVE FOR MANIFOLD MOUNTING MPKH3 – MPKH4 – STEEL

250 – 400 BAR Rated

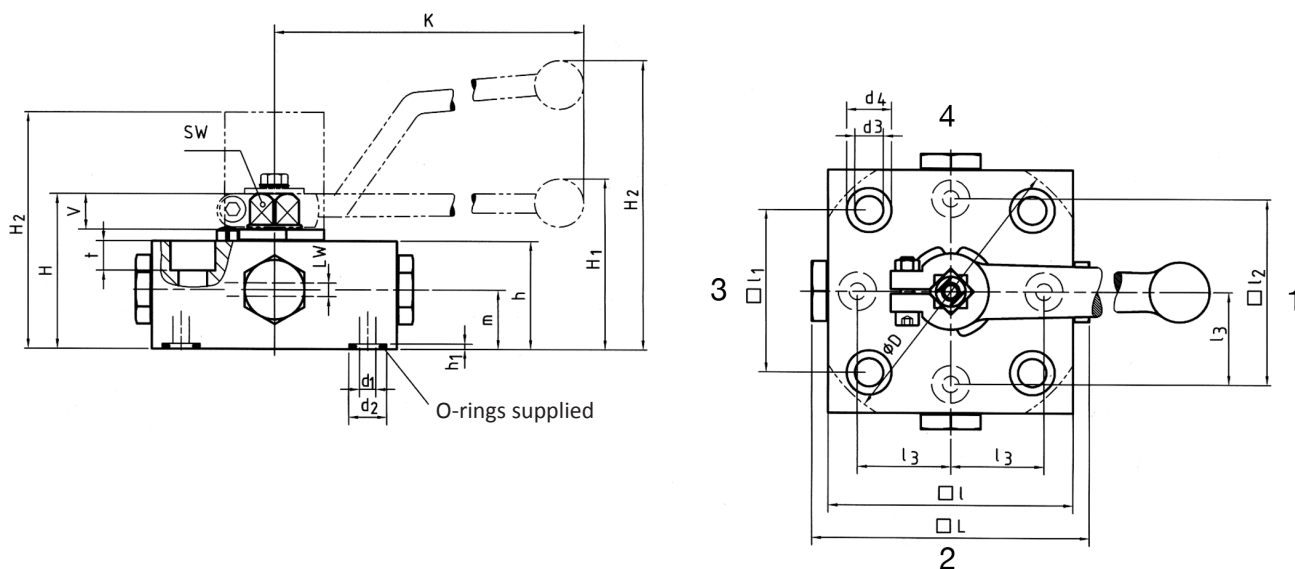

Dimensions



MPKH3

Type	DN	LW _{L/T}	I	I ₁	I ₂	I ₃	L	D	H	h	m	V	SW	K
MPKH3	6	5	90	70	-	34.3	102	-	58	40	22	13	12	160
MPKH3	10	8	100	80	-	40.5	111	-	68	50	27	14	14	200
MPKH3	13	13	140	90	-	57.7	154	150	78	60	31	14	14	200
MPKH3	20	18	171	100	-	68.5	184	180	88	67	36,5	16.5	17	320
MPKH3	25	23	205	115	-	81	225	215	96	75	40.5	16.5	17	320
MPKH3	32	32	260	148.5	-	90	288	275	147	115	62	26	22	600
MPKH3	40	38	301	155.5	-	103	332	315	156	125	65	25	22	600

MPKH4

Type	DN	LW _{L/T}	LW _x	I	I ₁	I ₂	I ₃	L	D	H	h	m	V	SW	K
MPKH4	6	5	4	90	70	68.6	-	102	-	58	40	22	13	12	160
MPKH4	10	8	7	100	80	81	-	111	-	68	50	27	14	14	200
MPKH4	13	13	10	140	90	115.4	-	154	150	78	60	31	14	14	200
MPKH4	20	18	14	171	100	137	-	184	180	88	67	36.5	16.5	17	320
MPKH4	25	23	16	205	115	162	-	225	215	96	75	40.5	16.5	17	320
MPKH4	32	32	25	260	148.5	180	-	288	275	147	115	62	26	22	600
MPKH4	40	38	32	301	155.5	206	-	332	315	156	125	65	25	22	600

These products are not 'PED Compliant' for use with GAS

Should you have a GAS application please contact our sales office in order that they can check the PED requirements and offer a CE marked suitable product.

MULTIWAY BALL VALVE FOR MANIFOLD MOUNTING MPKH3 – MPKH4 – STEEL

250 – 400 BAR Rated

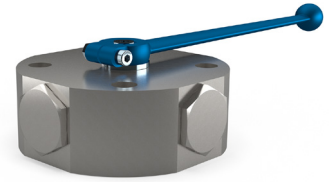

HIGH PRESSURE BALL VALVES

Materials

Body	Steel
Trunnion ball	Steel
Ball seats	POM
O-rings	NBR
Temp. range	-20°C to 100°C

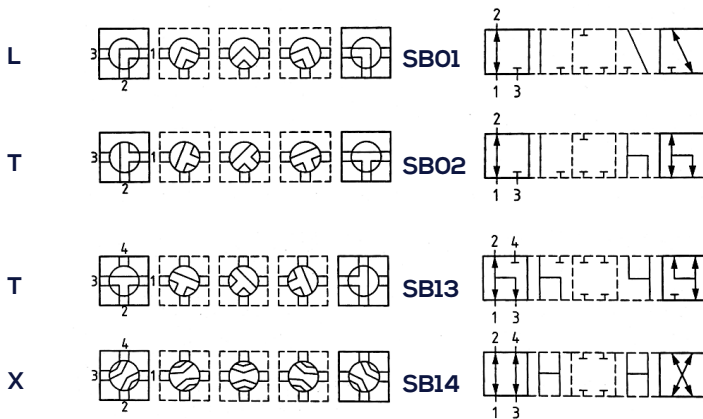

d_1	d_2	h_1	O-ring	D_3	D_4	t	Screws DN912	H_1	H_2	Weight kg	BAR
6	14	2	9x2.5	11	-	-	4 x M10 - 10.9	-	101	2.50	400
8	14.3	2	9.5x2.5	11	18	11	4 x M10 - 10.9	72	-	3.70	315
13	19.8	2	15x2.5	13.5	-	-	4 x M12 - 10.9	82	-	9.50	315
18	27.9	2.3	22x3	13.5	-	-	4 x M12 - 12.9	97	-	15.00	250
23	31.9	2.3	26x3	18	26	18	4 x M16 - 12.9	106	-	23.00	250
32	39.9	2.3	34x3	22	33	21.5	4 x M20 - 12.9	-	193	56.00	250
38	55.9	2.3	50x3	26	40	25.5	4 x M24 - 12.9	-	204	60.00	250

d_1	d_2	h_1	O-ring	D_3	D_4	t	Screws DN912	H_1	H_2	Weight kg	BAR
6	14	2	9x2,5	11	-	-	4 x M10 - 10.9	-	101	2.60	400
8	14.3	2	9.5x2.5	11	18	11	4 x M10 - 10.9	72	-	3.80	315
13	19.8	2	15x2.5	13.5	-	-	4 x M12 - 10.9	82	-	9.70	315
18	27.9	2.3	22x3	13.5	-	-	4 x M12 - 12.9	97	-	15.30	250
23	31.9	2.3	26x3	18	26	18	4 x M16 - 12.9	106	-	23.40	250
32	39.9	2.3	34x3	22	33	21.5	4 x M20 - 12.9	-	193	56.60	250
38	55.9	2.3	50x3	26	40	25.5	4 x M24 - 12.9	-	204	60.70	250

These products are not 'PED Compliant' for use with GAS

Should you have a GAS application please contact our sales office in order that they can check the PED requirements and offer a CE marked suitable product.