

WING LEVER  
AVAILABLE  
ON REQUEST

# HIGH PRESSURE 2-WAY BALL VALVES CARBON STEEL BKH SERIES

315 - 500 BAR Rated  
NPT Thread

Article no.	Thread NPT	Max Pressure BAR	Price £	Price €
101010	1/4"	500	ON REQUEST	
101011	3/8"	500	ON REQUEST	
9101012	1/2"	500	ON REQUEST	
9101013	3/4"	400	ON REQUEST	
9101014	1"	350	ON REQUEST	
9101014HP	1"	500	ON REQUEST	
101015	1 1/4"	315	ON REQUEST	

## Materials

Body	Steel 11SMn28K - Yellow Zinc Passivated
Ball	Brass - Mirror Finish Chromed
Stem Seal	NITRIL (Others On Request)
Ball Seal	POM-MoS2 (Others On Request)
Temp. Range	-20 to +100°C

## Dimensions

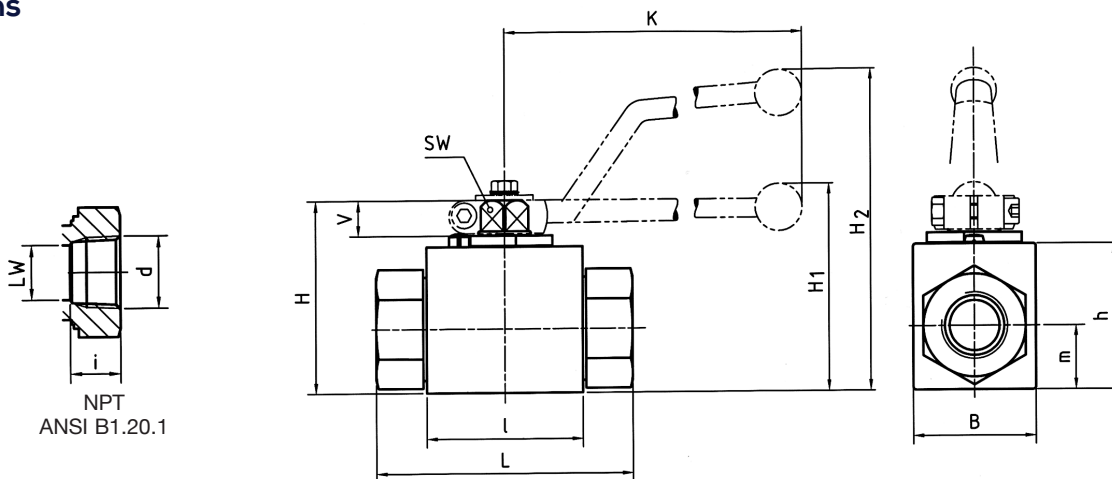

Type	DN	LW	L	I	B	H	h	m	V	SW	K	i	d	H1	H2	Weight
BKH-1/8"NPT	4	5	69	40	26	47	33	13,5	11	9	115	10.5	1/8"NPT	-	82	0.30
BKH-1/4"NPT	6	6	69	40	26	47	33	13,5	11	9	115	13.7	1/4"NPT	-	82	0.40
BKH-3/8"NPT	10	10	72	43	32	52	38	17,5	11	9	115	13.5	3/8"NPT	-	86	0.54
BKH-1/2"NPT	13	13	83	48	35	54	40	19	11	9	115	17	1/2"NPT	-	89	0.65
BKH-3/4"NPT	20	20	95	62	49	75	57	24,5	14	14	200	18.3	3/4"NPT	79	-	1.61
BKH-1"NPT	25	25	113	66	58	83	65	29,5	14	14	200	21.6	1"NPT	87	-	2.34
BKH-1 1/4"NPT	25/32	25	120	66	58	83	65	29,5	14	14	200	22.7	1 1/4"NPT	87	-	2.40
BKH-1 1/2"NPT	25/40	25	120	66	58	83	65	29,5	14	14	200	22.1	1 1/2"NPT	87	-	2.65

These products are not 'PED Compliant' for use with GAS

Should you have a GAS application please contact our sales office in order that they can check the PED requirements and offer a CE marked suitable product.