

HIGH PRESSURE 2-WAY BALL VALVES CARBON STEEL BKH SERIES

315 - 500 BAR Rated BSP Parallel

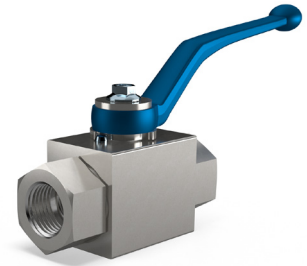

WING LEVER
AVAILABLE
ON REQUEST

Article no.	Thread BSP	Max Pressure BAR	Price £	Price €
101001	1/8"	500	ON REQUEST	
9101002	1/4"	500	ON REQUEST	
9101003	3/8"	500	ON REQUEST	
9101004	1/2"	500	ON REQUEST	
9101005	3/4"	400	ON REQUEST	
9101006	1"	350	ON REQUEST	
9101007	1 1/4" *	315	ON REQUEST	
101008	1 1/2" *	315	ON REQUEST	

* DN25 REDUCED BORE

Materials

Body	Steel 115Mn28K - Yellow Zinc Passivated
Ball	Brass - Mirror Finish Chromed
Stem Seal	NITRIL (Others On Request)
Ball Seal	POM-MoS2 (Others On Request)
Temp. range	-20 to +100°C

Dimensions

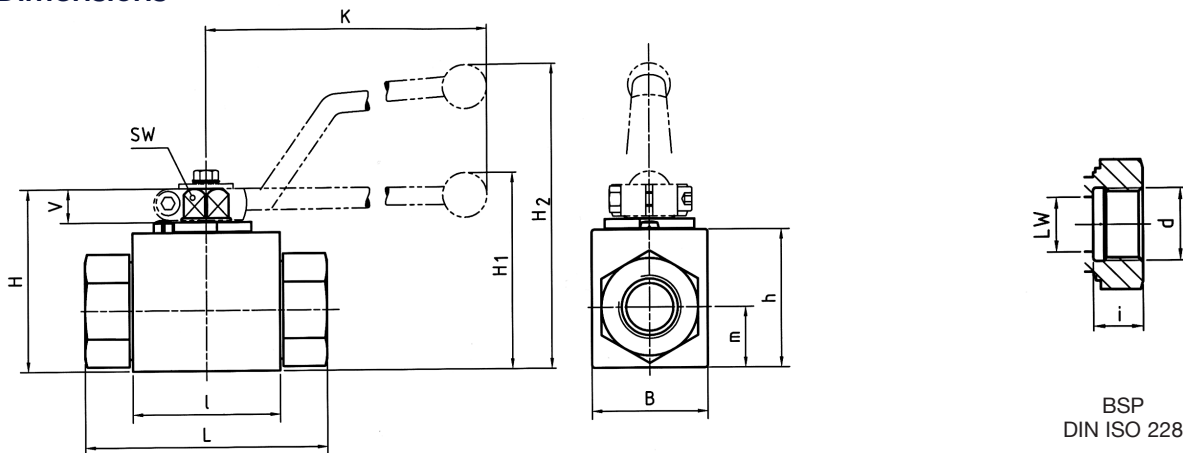

BSP
DIN ISO 228

Type	DN	LW	L	I	B	H	h	m	V	SW	K	i	d	H1	H2	Weight
BKH-G1/8	4	5	69	40	26	47	33	13,5	11	9	115	10	G1/8	-	82	0.41
BKH-G1/4	6	6	69	40	26	47	33	13,5	11	9	115	14	G1/4	-	82	0.40
BKH-G3/8	10	10	72	43	32	52	38	17,5	11	9	115	14	G3/8	-	86	0.54
BKH-G1/2	13	13	83	48	35	54	40	19	11	9	115	16,3	G1/2	-	89	0.65
BKH-G1/2	16	15	83	48	38	63	46	19	13	12	160	16,3	G1/2	-	106	0.70
BKH-G5/8	13	13	83	48	35	54	40	19	11	9	115	16	G5/8	-	89	0.61
BKH-G5/8	16	15	83	48	38	63	46	19	13	12	160	16	G5/8	-	106	0.70
BKH-G3/4	20	20	95	62	49	75	57	24,5	14	14	200	18	G3/4	79	-	1.50
BKH-G1	25	25	113	66	58	83	65	29,5	14	14	200	20	G1	87	-	2.20
BKH-G1 1/4	25/32	25	120	66	58	83	65	29,5	14	14	200	22	G1 1/4	87	-	2.30
BKH-G1 1/2	25/40	25	130	66	58	83	65	29,5	14	14	200	24	G1 1/2	87	-	2.60

These products are not 'PED Compliant' for use with GAS

Should you have a GAS application please contact our sales office in order that they can check the PED requirements and offer a CE marked suitable product.