

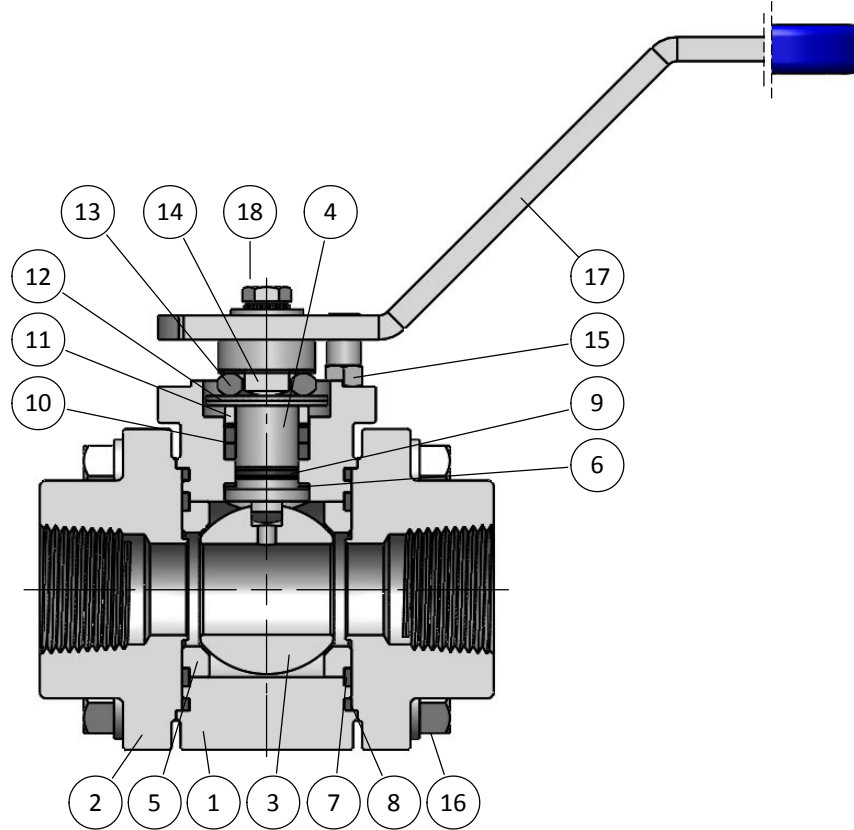

XFM-A SERIES
CL600 (1500 psi)
FULL BORE - DN 10 (3/8") ÷ 50 (2")
REDUCED BORE - DN 15 (1/2") ÷ 65 (2 1/2")
STANDARD
BILL OF MATERIALS

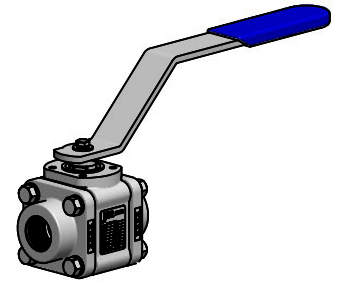

BILL OF MATERIALS

Part	Qt.	Description	CARBON STEEL VERSION	STAINLESS STEEL VERSION
1	1	Body	A216 WCB	A351 CF3M
2	2	End	A216 WCB	A351 CF3M
3	1	Ball	A351 CF8M + TCC	
4	1	Stem	A564 S17400	
5	2	Seat	A479 316/L + TCC	
6	1	Stem Thrust Seals	↘	C-RPTFE + PEEK
7	2	1st Body Seal	↘	GRAPHITE
8	2	2nd Body Seal	↘	GRAPHITE
9	1	O'Ring	↘	FKM
10	1	Stem Packing Set	↘	GRAPHITE + PEEK
11	1	Gland Packing	STAINLESS ST. 316	
12	2	Disc Spring	STAINLESS ST. 316	
13	1	Stem Nut	STAINLESS ST. 316	
14	1	Locking Clip	STAINLESS ST. 316	
15	1	Stop Pin	STAINLESS ST. 316	
16	8	Bolt	A193 Gr. B7 ZINC.	A193 Gr. B8M cl.2
17	1	Handle	CARBON ST. ZINC. / VINYL	
18	1	Handle Fastener	STAINLESS ST. 316	

↘ TYPICAL SPARE PARTS

XFM-A SERIES

CL600 (1500 psi)
 FULL BORE - DN 10 (3/8") ÷ 50 (2")
 REDUCED BORE - DN 15 (1/2") ÷ 65 (2 1/2")
 THREADED & WELDED ENDS

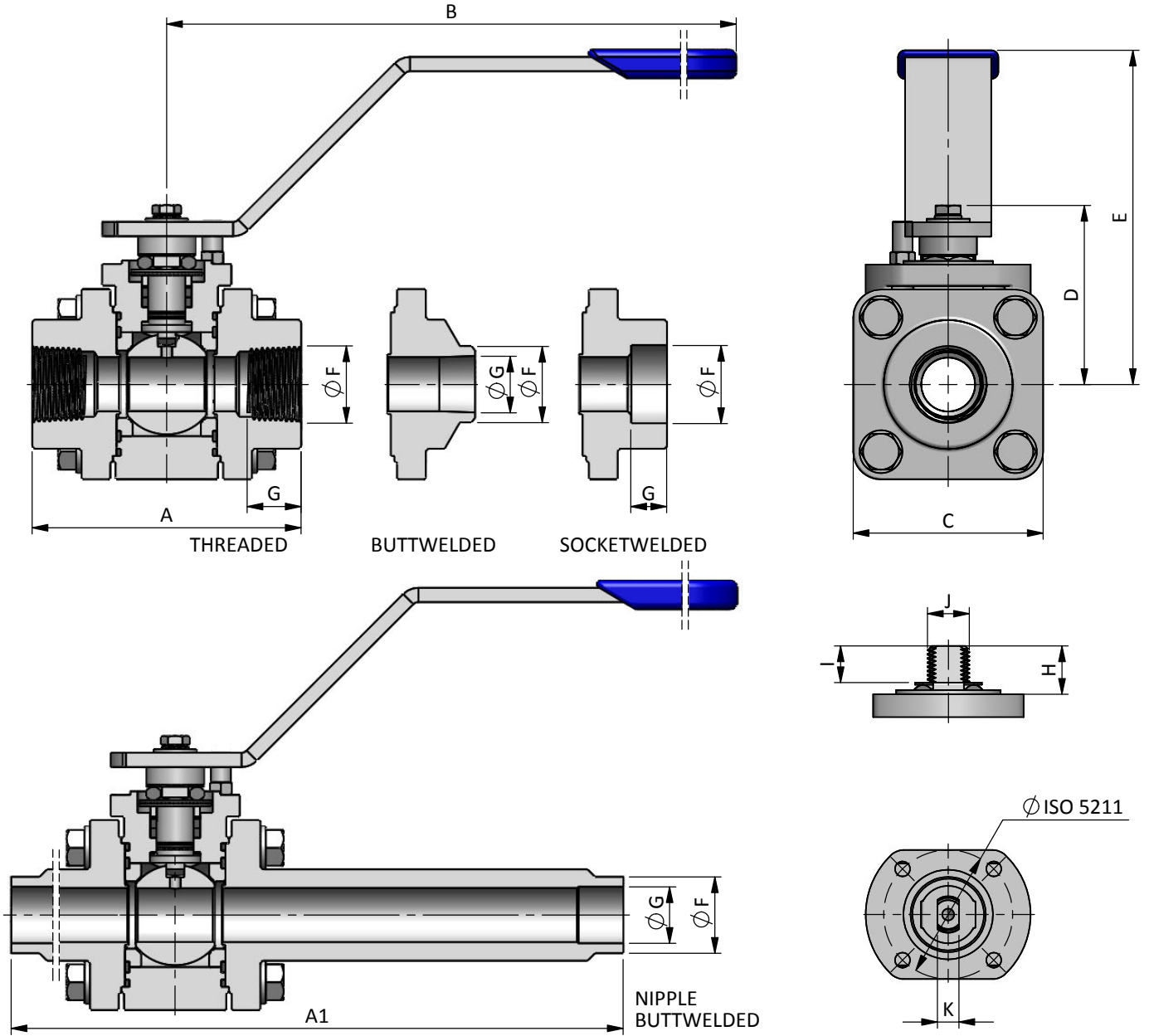
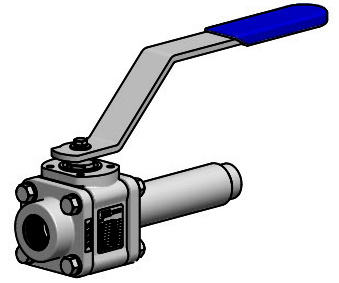

DN / Size				Dimensions								Automation					Weight Approx. [kg]		
FULL BORE		REDUCED BORE		Ball Port	A	A1	B	C	D	E	F	G	H	I	J	K	ISO 5211	Short	Long
mm	inch	mm	inch																
10	3/8"	15	1/2"	11.9	70	-	200	48	46.5	87.5	NPT BSPT BSP BW SW	10	7	10	6	F03	1	-	
15	1/2"	20	3/4"	15.1	75	250	200	53	50	90		10	7	10	6	F03	1.2	1.6	
20	3/4"	25	1"	20.6	90	260	230	64.5	62.5	101.5		16.5	9.5	12	7.5	F04	2	2.5	
25	1"	32	1 1/4"	25.4	100	270	230	72	66.5	105		16.5	9.5	12	7.5	F04	3	3.5	
32	1 1/4"	40	1 1/2"	31.8	115	280	350	86	81.5	125		21.5	12	16	11	F05	4.5	6	
40	1 1/2"	50	2"	38.1	125	290	350	96	86.5	131.5		22	12	16	11	F05	6	7	
50*	2"	65	2 1/2"	49.0	165	310	420	ø144	112.5	155		29	17.5	20	14	F07	10.5	11.5	

Nipple butt weld only available in full bore version
 DN65 Reduced bore only available in Butt weld version

*Valve construction is similar to DN65 ÷ DN100 (page 4-5)

XFM-A SERIES
CL400/300 (1000/750 psi)
FULL BORE - DN 65 (2½") ÷ 100 (4")
REDUCED BORE - DN 80 (3") ÷ 100 (4")
STANDARD
BILL OF MATERIALS

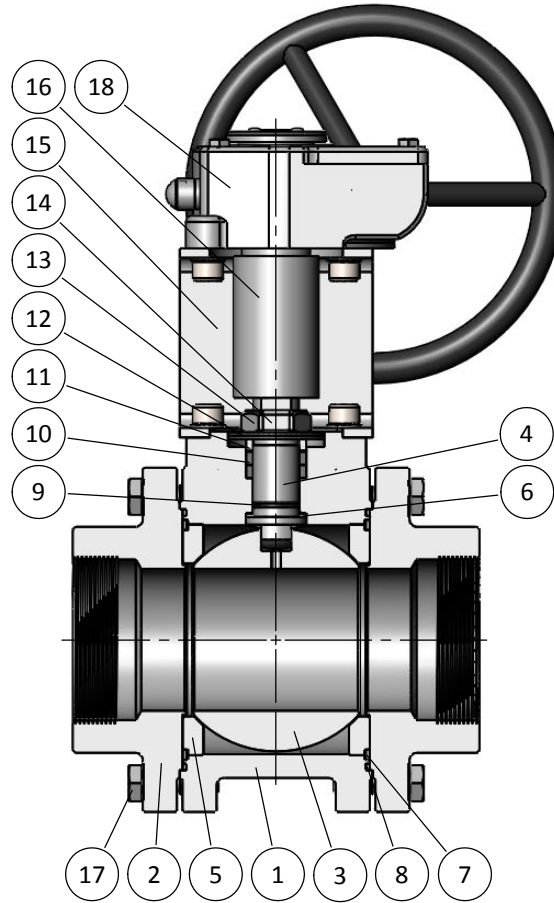

BILL OF MATERIALS

Part	Qt.	Description	CARBON STEEL VERSION	STAINLESS STEEL VERSION
1	1	Body	A216 WCB	A351 CF3M
2	2	End	A216 WCB	A351 CF3M
3	1	Ball	A351 CF8M + TCC	
4	1	Stem	A564 S17400	
5	2	Seat	A479 316/L + TCC	
6	1	Stem Thrust Seals	↘	C-RPTFE + PEEK
7	2	1st Body Seal	↘	C-RPTFE
8	2	2nd Body Seal	↘	GRAPHITE
9	1	O'Ring	↘	FKM
10	1	Stem Packing Set	↘	GRAPHITE + PEEK
11	1	Gland Packing	STAINLESS ST. 316	
12	1/2	Disc Spring	STAINLESS ST. 316	
13	1	Stem Nut	STAINLESS ST. 316	
14	1	Locking Clip	STAINLESS ST. 316	
15	1	Bracket	STAINLESS ST. 304	
16	1	Bracket Stem	A564 S17400	
17	-	Bolt	A193 Gr. B7 ZINC.	A193 B8M cl.2
18	1	Gearbox	CAST IRON	

↘ TYPICAL SPARE PARTS

XFM-A SERIES
CL400/300 (1000/750 psi)
FULL BORE - DN 65 (2½") ÷ 100 (4")
REDUCED BORE - DN 80 (3") ÷ 100 (4")
THREADED & WELDED ENDS

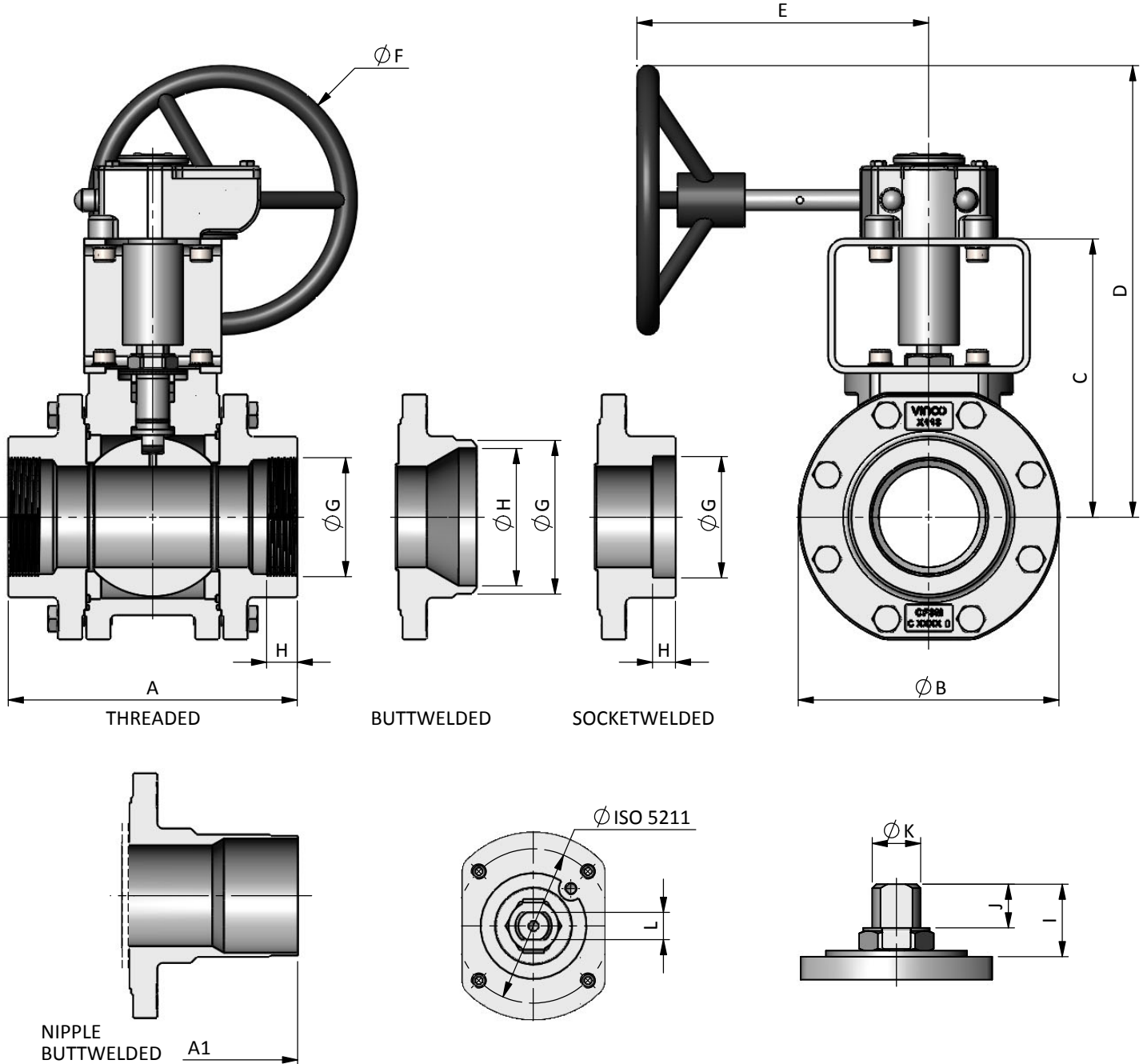
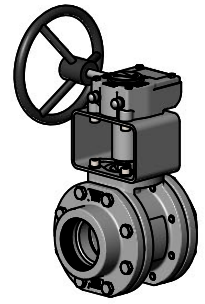

DN / Size				Dimensions								Automation					Weight Approx. [kg]			
FULL BORE		REDUCED BORE		Ball Port	A	A1	B	C	D	E	F	G	H	I	J	K	L	ISO 5211	Short	Long
mm	inch	mm	inch																	
65	2½"	80	3"	62	190	330	174	150	280	220	200	NPT BSPT BSP BW SW	41.5	26.5	24	18	F07	22.5	23	
80	3"	100	4"	75	215	350	194	210	335	220	200		36	21	24	18	F10	27	28.5	
100	4"	N/A		100	265	390	244	235	425	285	300		50.5	28.5	30	22	F10	56	57.5	

Reduced bore only available in Buttweld version

XFM-A SERIES
CL600 (1500 psi)
FULL BORE - DN 10 (3/8") ÷ 100 (4")
REDUCED BORE - DN 15 (1/2") ÷ 100 (4")
LOCKING DEVICE

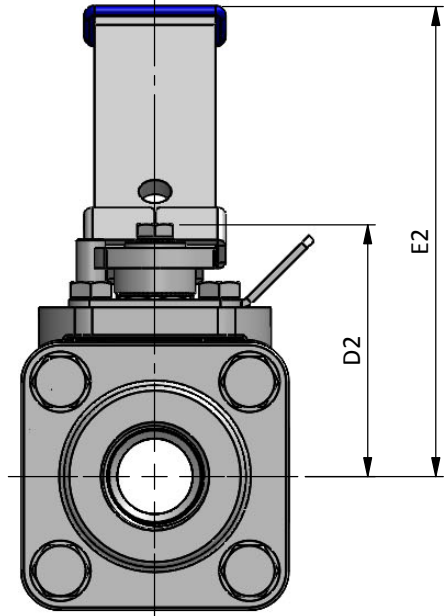
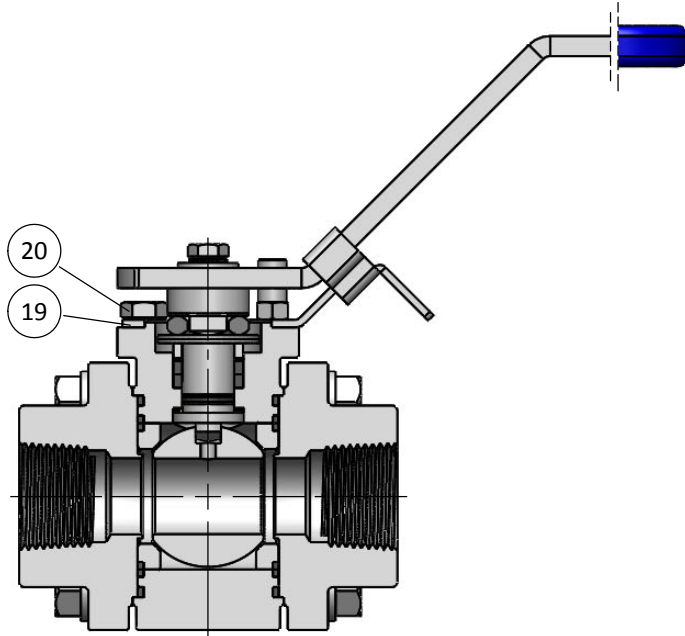
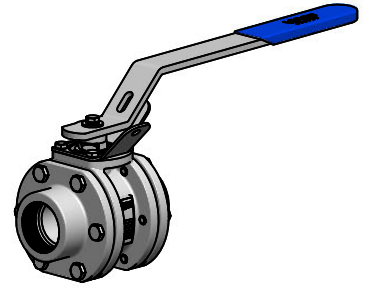

BILL OF MATERIALS

Part	Qt.	Description	Material
19	1	Locking Plate	CARBON ST. ZINC.
20	3	Bolt	STAINLESS ST. 304

DN / Size				D2	E2
FULL BORE		REDUCED BORE			
mm	inch	mm	inch		
10	3/8"	15	1/2"	46.5	87.5
15	1/2"	20	3/4"	50	90
20	3/4"	25	1"	62.5	101.5
25	1"	32	1 1/4"	66.5	105
32	1 1/4"	40	1 1/2"	81.5	125
40	1 1/2"	50	2"	86.5	131.5
50	2"	65	2 1/2"	112.5	155

Larger size valves available with lockable gearboxes

XFM-A SERIES
CL600/400/300 (1500/1000/750 psi)
FULL BORE - DN 10 (3/8") ÷ 100 (4")
REDUCED BORE - DN 15 (1/2") ÷ 100 (4")
BRACKET FOR AUTOMATION

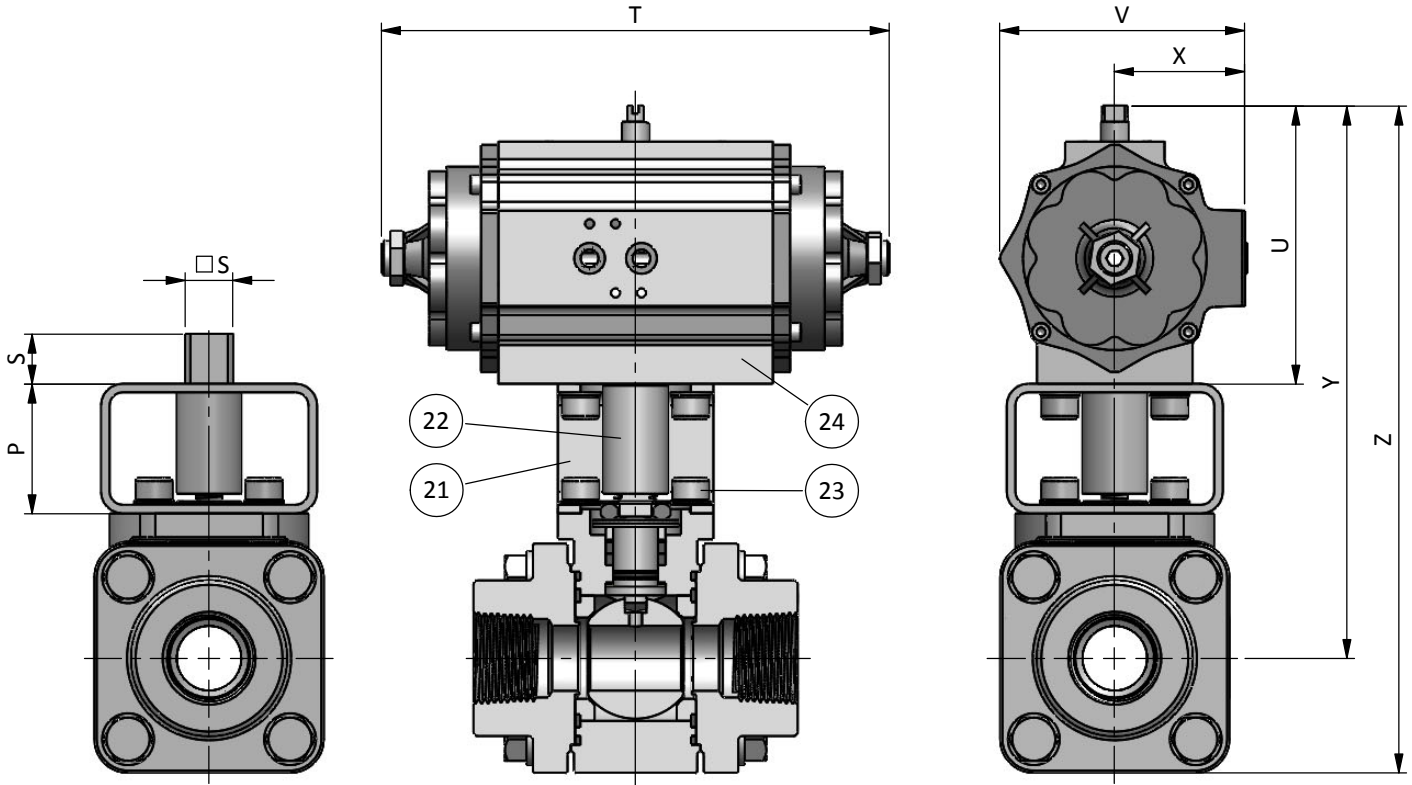
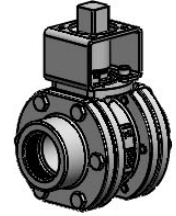

BILL OF MATERIALS

Part	Qt.	Description	Material
21	1	Bracket	A351 CF8M / STAINLESS ST. 304
22	1	Stem Extension	A564 S17400
23	8	Bolt	STAINLESS ST. 316
24	1	Pneumatic Actuator	ALUMINIUM

DN / Size				Automation			Actuator *						
FULL BORE		REDUCED BORE		P	S	ISO 5211	REF.	T	U	V	X	Y	Z
mm	inch	mm	inch										
10	3/8"	15	1/2"	30	17	F05	008-10	233	131	112	57	195	215
15	1/2"	20	3/4"	30	17	F05	008-10	233	131	112	57	195	220
20	3/4"	25	1"	40	19	F05	012-08	280	131	112	57	215	245
25	1"	32	1 1/4"	40	22	F07	020-14	294	151	133	70	235	270
32	1 1/4"	40	1 1/2"	50	22	F07	030-18	286	189	169	85	295	335
40	1 1/2"	50	2"	50	27	F07	040-18	344	199	169	85	310	355
50	2"	65	2 1/2"	60	27	F07	060-20	377	230	195	100	365	430
65	2 1/2"	80	3"	60	27	F07	060-20	377	230	195	100	385	460
80	3"	100	4"	100	36	F10	140-24	445	272	232	120	480	570
100	4"	N/A		100	46	F14	200-20	537	272	232	120	505	620

*Pneumatic Actuators selected for TCC seats considering input air pressure of 5.5bar and minimum 25% safety margin

XFM-A SERIES
CL600/400/300 (1500/1000/750 psi)
FULL BORE - DN 10 (3/8") ÷ 100 (4")
REDUCED BORE - DN 15 (1/2") ÷ 100 (4")
EXTENDED STEM

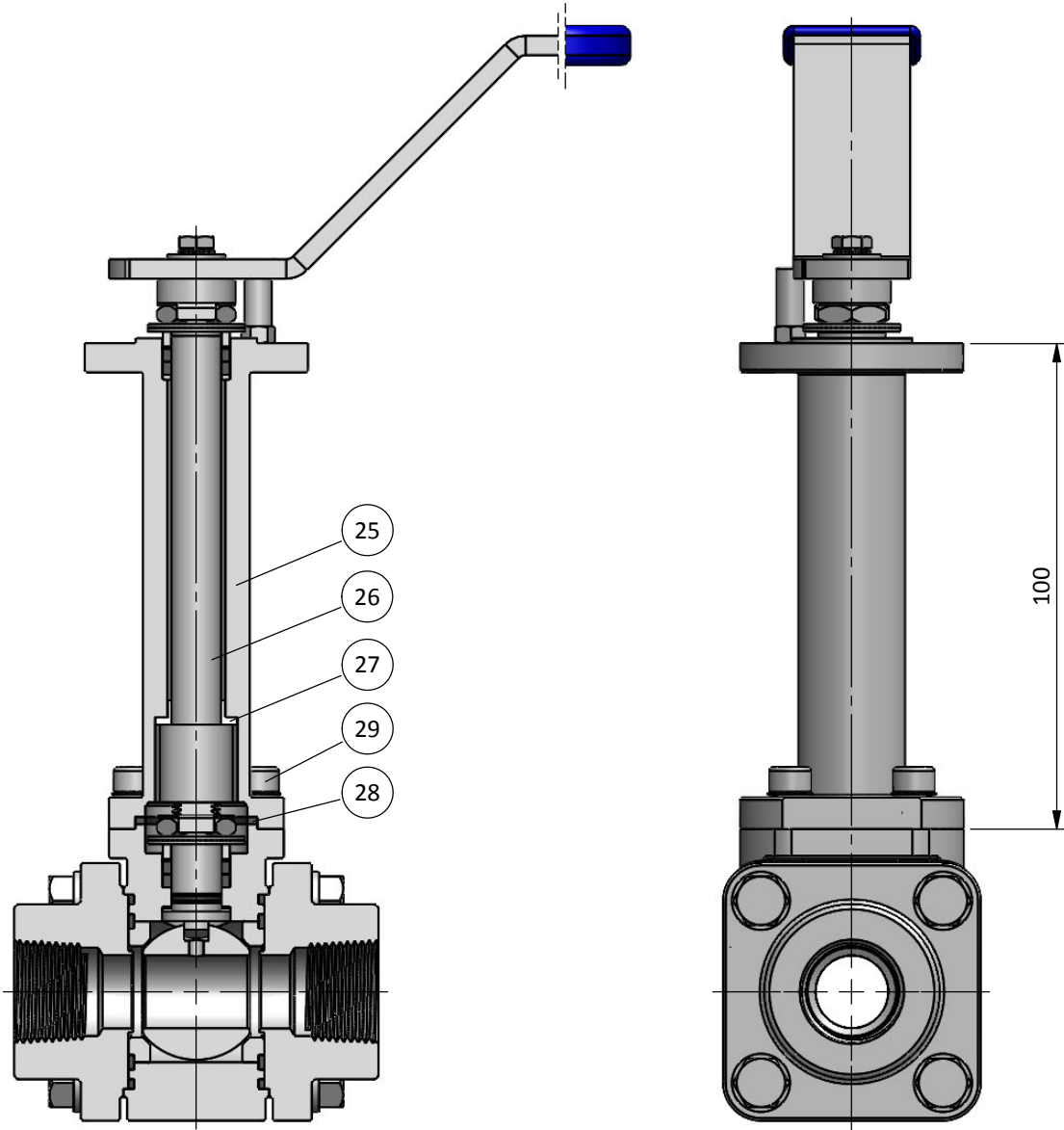
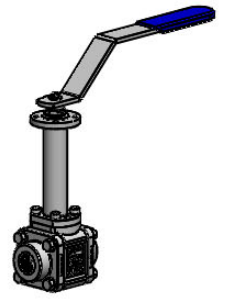

BILL OF MATERIALS

Part	Qt.	Description	CARBON STEEL VERSION	STAINLESS STEEL VERSION
25	1	Extension	A350 LF2 cl.1	A479 316/L
26	1	Stem Extension	A564 S17400	
27	1	Bearing	↘	TFM 1600
28	1	Extension Seal	↘	GRAPHITE
29	4	Bolt	STAINLESS ST. 316	



XFM-A SERIES

CL600/400/300 (1500/1000/750 psi)
 FULL BORE - DN 10 (3/8") ÷ 100 (4")
 REDUCED BORE - DN 15 (1/2") ÷ 100 (4")
TECHNICAL SPECIFICATIONS

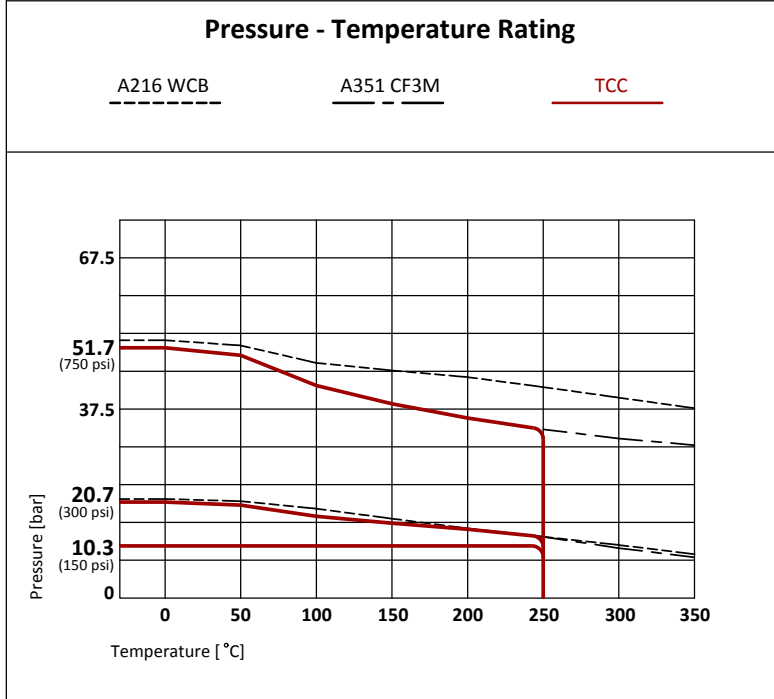

Working Conditions			
Material		mOT* [°C]	MOT* [°C]
A216 WCB	TCC	-29	250
A351 CF3M	TCC	-100	-50
			250

*mOT - minimum Operating Temperature.
 *MOT - Maximum Operating Temperature.
 Standard version recommended down to -50 °C
 *Extended version recommended down to -100 C

TCC - Tungsten Carbide Coating

Tungsten Carbide Coating applied in the contact surfaces of the ball and seats, with a minimum specified thickness of 200 µm, increases the hardness (up to 70 HRC) and the resistance to wearing conditions (abrasion, friction, others). This technology combined with a lapping process improves the sealing effect and the operation lifetime expectancy without maintenance under severe working conditions.

DN	Rating
FB 10 (3/8") to 50 (2") RB 15 (1/2") to 65 (2 1/2")	51.7 bar / 750 psi
FB 65 (2 1/2") to 80 (3") RB 80 (3") to 100 (4")	20.7 bar / 300 psi
FB 100 (4")	10.3 Bar / 150 psi

DN / Size				Class	Rating [bar]	Torque Valve Figure [Nm] *	Maximum Allowable Stem Torque [Nm]				Flow Coefficient Cv	
FULL BORE		REDUCED BORE					BTO	S31803	S32760	S17400		718
mm	inch	mm	inch				TCC	MAST				
10	3/8"	15	1/2"	Cl600	51.7	15	25	30	40	53.5	12	
15	1/2"	20	3/4"	Cl600	51.7	20	25	30	40	53.5	20	
20	3/4"	25	1"	Cl600	51.7	30	45	55	71.5	98.5	45	
25	1"	32	1 1/4"	Cl600	51.7	50	45	55	71.5	98.5	75	
32	1 1/4"	40	1 1/2"	Cl600	51.7	70	125	150	200	275	105	
40	1 1/2"	50	2"	Cl600	51.7	100	125	150	200	275	175	
50	2"	65	2 1/2"	Cl600	51.7	150	240	290	385	535	300	
65	2 1/2"	80	3"	Cl400	20.7	150	445	540	715	1000	500	
80	3"	100	4"	Cl400	20.7	250	445	540	715	1000	1000	
100	4"	N/A		Cl300	10.3	350	880	1075	1420	1950	2000	

*Values without safety margin

Reference BTO 100% - RTO 55% | ETO 75% | BTC 75% | RTC 55% | ETC 80%

CERTIFICATION	CONSTRUCTION STANDARDS	TEST STANDARDS
CE Certification acc. to PED 2014/68/EU Fire Safe Design acc. to API 607Ed.6/ISO 10497 ATEX II 2GD Design acc. to 2014/34/EU Fugitive Emissions Class B acc. to ISO 15848 CO1 (-46 °C to RT) Quality System Certified acc. to ISO 9001	ASME B16.34 ISO 17292 ASME B1.20.1 ISO 7-1 ISO 228-1 ASME B16.25 ASME B36.10M ASME B16.11 MSS-SP-25 ISO 5211	Pressure tests according to: EN 12266-1 / API 598 / ISO 5208 Rate D Tests applied: Hydrostatic Shell Test Hydrostatic Seat Test Pneumatic Tightness Test Pneumatic Seat Test EN 10204 type 3.1 Certificate

Standards acc. to the latest available revision

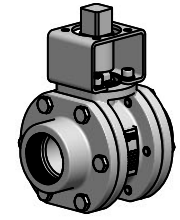
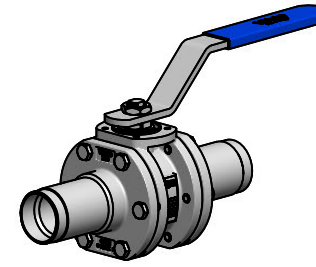
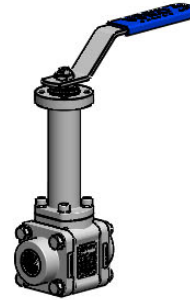

SERIE	CLASS	VERSION	PORT	DN	ENDS	BODY	BALL STEM	BOLTING	SEATS 1°SEAL	PACKING 2°SEAL O'RING	OPTIONS
XFM-A		1	F - FB	010	BUTTWELD	A - A216 WCB	E - A351 CF8M + TCC A564 S17400	A - B7	1 - A479 316/L + TCC Graphite	1 - Graphite Graphite FKM	A - 2 Opposite sides Flattened Ends
			R - RB	015	B1 - BW SCH 10	C - A351 CF3M	Z - Others	F - B8M cl.2	9 - Others		C - Spring Return
3 - CL600				020	B2 - BW SCH 40	Z - Others					D - Simple Extension 60 mm
				025	B3 - BW SCH 80						E - Extension 100 mm
				032	B6 - ISO 1127 S1						F - Bracket Automation
				040	B9 - OTHERS						G - Gear Box
				050	SOCKETWELD						H - Actuators
3 - CL400				065	C1 - SW ASME B16.11						I - Switch Box / Limit Swiches
				080	C9 - OTHERS						L - Locking Lever/Handle
2 - CL300				100	THREADED						O - Oval Lever/Handle
				D1 - BSP - ISO 228/1							R - Bare Shaft / Bare Stem
				D2 - BSPT - ISO 7/1							S - Solenoid Valve
				D3 - NPT - B1.20.1							Y - Full Execution SS.316
				D9 - OTHERS							Z - Others
				INTEGRAL NIPPLE *							
				N1 - BW SCH 10							
				N2 - BW SCH 40							
				N3 - BW SCH 80							
				N6 - BW ISO 1127 S1							
				N9 - OTHERS							
				WELDED BLOCK							
				W10C - BLOCK 100							
W50C - BLOCK 500											

*Except DN10 FB

Example:

XFM-A21F015B1D3AEA11

XFM-A21F100N1N1CEF11H

METALLIC SEATS RANGE

METALLIC SEATS RANGE
CFM / BFM / XFM / SFM / VTM



INDUSTRIAL RANGE

CF Series
2 split body - Floating
Cl 150/300
DN ½" (15) to 4" (100)



BF Series
2 split body - Floating
Cl 150 to 600
DN ½" (15) to 4" (100)



SF Series
3 pieces bolted - Floating
Cl 300 to 800
DN ½" (15) to 4" (100)



HF Series
3 pieces bolted - Floating
Cl 1500/2500
DN ½" (15) to 1½" (40)

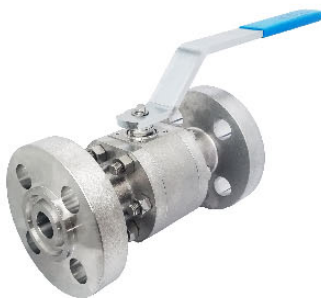

ST Series
Multi-ways - Floating
Cl 150 to 600
DN ¾" (10) to 2" (50)



VTR Series
3 pieces bolted - Trunnion
Cl 150 to 2500
DN ½" (15) to 12" (300)



OTHER RANGE

SANITARY RANGE
XP / RP / LP / MP / QP



CRYOGENIC RANGE
CXF / CCF / CBF / CSF / CVT



