

**BILL OF MATERIALS**

Part	Qt.	Description	CARBON STEEL VERSION	LT CARBON STEEL VERSION	STAINLESS STEEL VERSION
1	1	Body	1.0619	1.6220	1.4408
2	1	End	1.0619	1.6220	1.4408
3	1	Ball	A351 CF8M		
4	1	Stem	A479 316/L		
5	2	Seat	C-RPTFE		
6	1	Stem Thrust Seals	C-RPTFE + PEEK		
7	1	1st Body Seal	C-RPTFE		
8	1	2nd Body Seal	GRAPHITE		
9	1	O'Ring	FKM AED		
10	1	Stem Packing Set	GRAPHITE + PEEK		
11	1	Gland Packing	STAINLESS ST. 316		
12	2	Disc Spring	STAINLESS ST. 316		
13	1	Stem Nut	STAINLESS ST. 316		
14	1	Locking Clip	STAINLESS ST. 316		
15	1	Stop Pin	STAINLESS ST. 316		
16	-	Stud	Gr.8.8 Zinc.	A4 CL.70	
17	-	Nut	Gr. 8 Zinc.	A4 CL.70	
18	1	Handle	A351 CF8		
19	1	Handle Fastener	STAINLESS ST. 304		

↘ TYPICAL SPARE PARTS

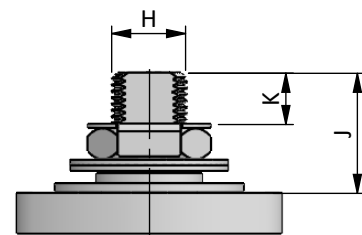
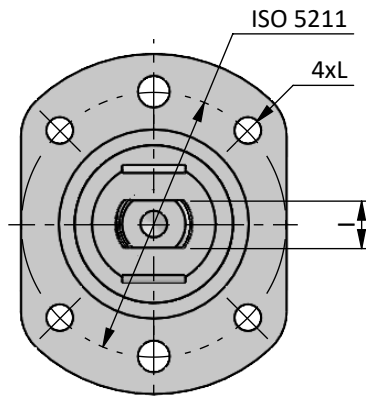
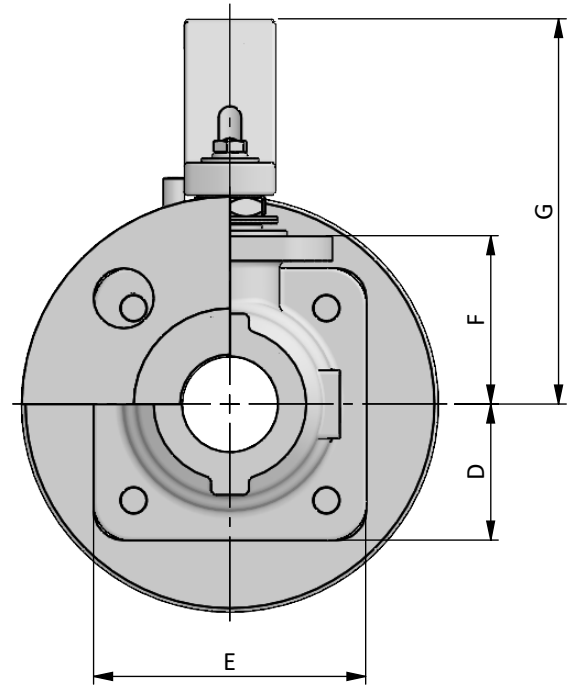
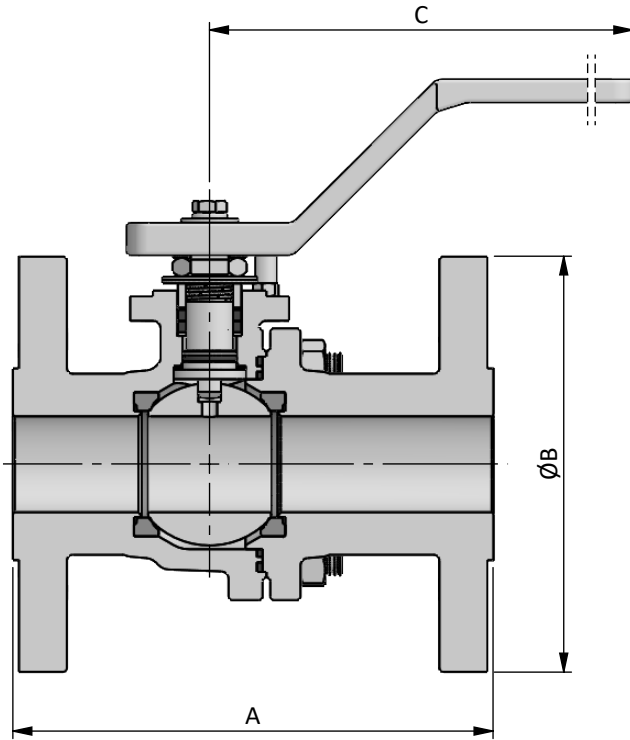
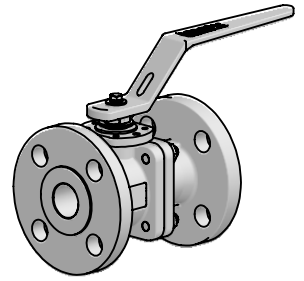

DN / Size		Dimensions										Automation					Weight Approx. [kg]		
FULL BORE	Ball Port	PN40				C	D	E	F	G	H	I	J	K	L	ISO 5211	F1	F4	
		F1		F4															
mm	inch	A	B	A	B														
15	½"	15.1	130	95	115	95	180	27.5	55	35	90	10	6	15	5.5	M5	F04	3	2.5
20	¾"	20.6	150	105	120	105	180	32.5	65	40	100	12	7.5	20	8	M5	F04	4	3.5
25	1"	25.4	160	115	125	115	180	37.5	75	45	105	12	7.5	20	8	M5	F04	4.5	4
32	1¼"	31.8	180	140	130	140	210	42.5	85	55	125	16	11	22	8.5	M6	F05	6.5	6
40	1½"	38.1	200	150	140	150	210	47.5	95	60	130	16	11	22	8.5	M6	F05	8.5	7.5

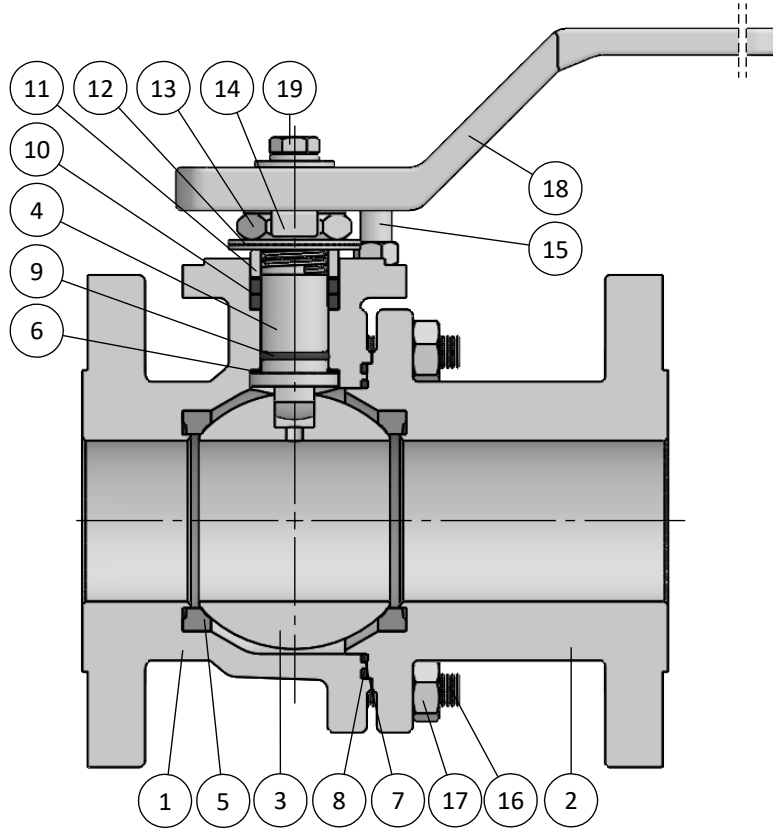
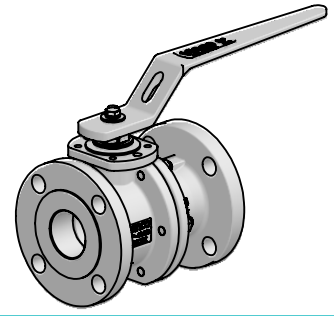

**BILL OF MATERIALS**

Part	Qt.	Description	CARBON STEEL VERSION	LT CARBON STEEL VERSION	STAINLESS STEEL VERSION
1	1	Body	1.0619	1.6220	1.4408
2	1	End	1.0619	1.6220	1.4408
3	1	Ball	A351 CF8M		
4	1	Stem	A479 316/L		
5	2	Seat	↙	C-RPTFE	
6	1	Stem Thrust Seals	↙	C-RPTFE + PEEK	
7	1	1st Body Seal	↙	C-RPTFE	
8	1	2nd Body Seal	↙	GRAPHITE	
9	1	O'Ring	↙	FKM AED	
10	1	Stem Packing Set	↙	GRAPHITE + PEEK	
11	1	Gland Packing	STAINLESS ST. 316		
12	2	Disc Spring	STAINLESS ST. 316		
13	1	Stem Nut	STAINLESS ST. 316		
14	1	Locking Clip	STAINLESS ST. 316		
15	1	Stop Pin	STAINLESS ST. 316		
16	-	Stud	Gr.8.8 Zinc.	A4 CL.70	
17	-	Nut	Gr. 8 Zinc.	A4 CL.70	
18	1	Handle	A351 CF8		
19	1	Handle Fastener	STAINLESS ST. 304		

↙ TYPICAL SPARE PARTS

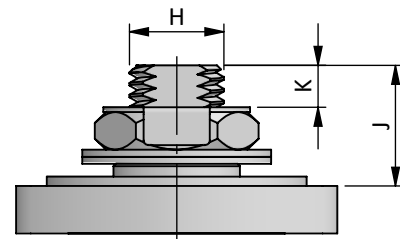
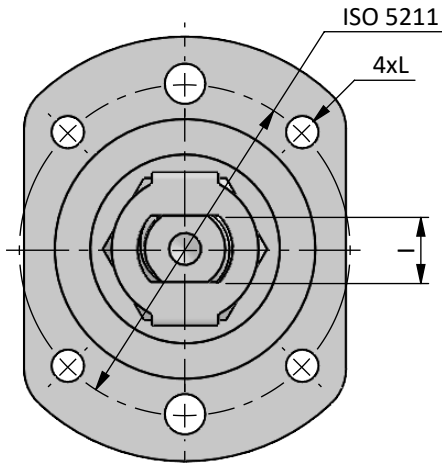
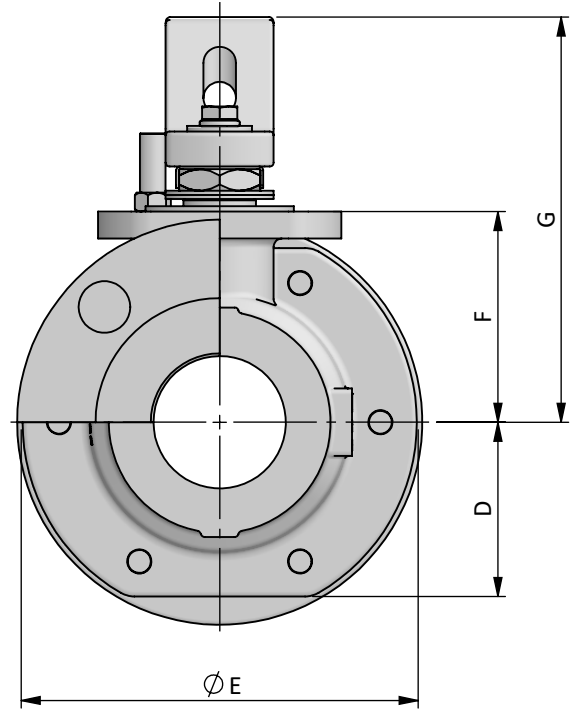
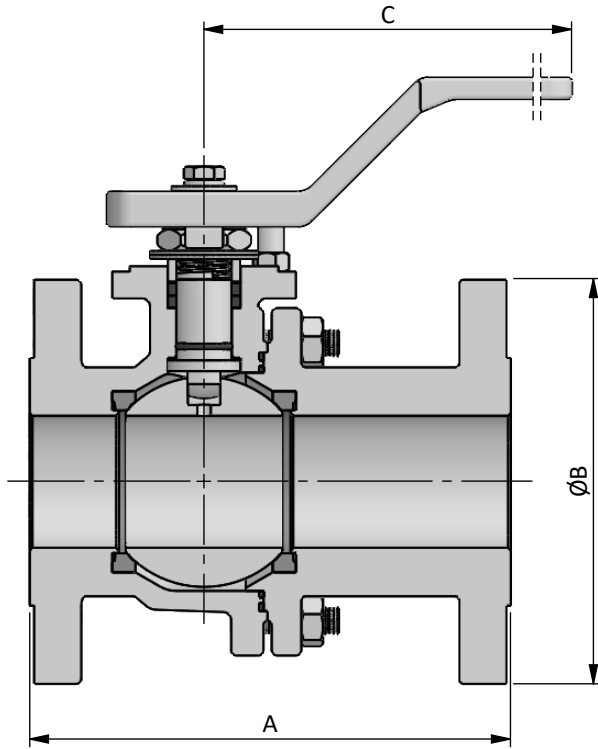
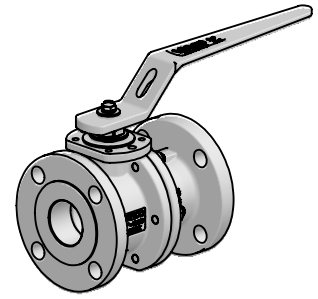

DN / Size		Dimensions													Automation					Weight Approx. [kg]					
FULL BORE	Ball Port	PN16				PN40				C	D	E	F	G	H	I	J	K	L	ISO 5211	PN16		PN40		
		F1		F4		F1		F4													F1	F4	F1	F4	
		A	B	A	B	A	B	A	B												F1	F4	F1	F4	
50	2"	49	-	-	-	230	165	150	165	300	65	145	80	150	20	14	26	9	M8	F07	-	-	14	12	
65	2½"	62	290	185	170	185	290	185	170	185	360	80	175	95	175	24	18	35	14.5	M8	F07	18	14	20	17
80	3"	75	310	200	180	200	310	200	180	200	420	90	200	105	190	24	18	35	12	M10	F10	26	22	30	25
100	4"	100	350	220	190	220	350	235	190	235	480	115	250	135	225	30	22	42.5	16.5	M10	F10	40	35	45	36

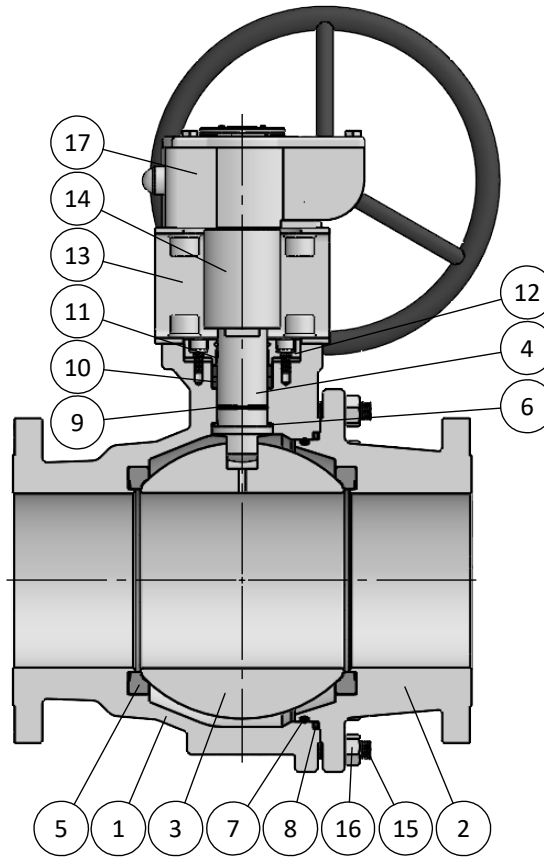
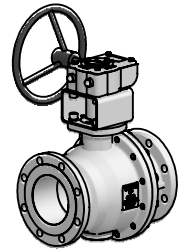

**BILL OF MATERIALS**

Part	Qt.	Description	CARBON STEEL VERSION	LT CARBON STEEL VERSION	STAINLESS STEEL VERSION
1	1	Body	1.0619	1.6220	1.4408
2	1	End	1.0619	1.6220	1.4408
3	1	Ball	A351 CF8M		
4	1	Stem	A479 316/L		
5	2	Seat	↙	C-RPTFE	
6	1	Stem Thrust Seals	↙	C-RPTFE + PEEK	
7	1	Body O'Ring	↙	FKM AED	
8	1	Body Seal	↙	GRAPHITE	
9	1	O'Ring	↙	FKM AED	
10	1	Stem Packing Set	↙	GRAPHITE + PEEK	
11	1	Bearing	↙	PTFE	
12	1	Gland Packing	A479 316/L		
13	1	Bracket	STAINLESS ST.304		
14	1	Bracket Stem	A479 316/L		
15	-	Stud	Gr.8.8 Zinc.	A4 CL.70	
16	-	Nut	Gr. 8 Zinc.	A4 CL.70	
17	1	Gearbox	CAST IRON		

↙ TYPICAL SPARE PARTS

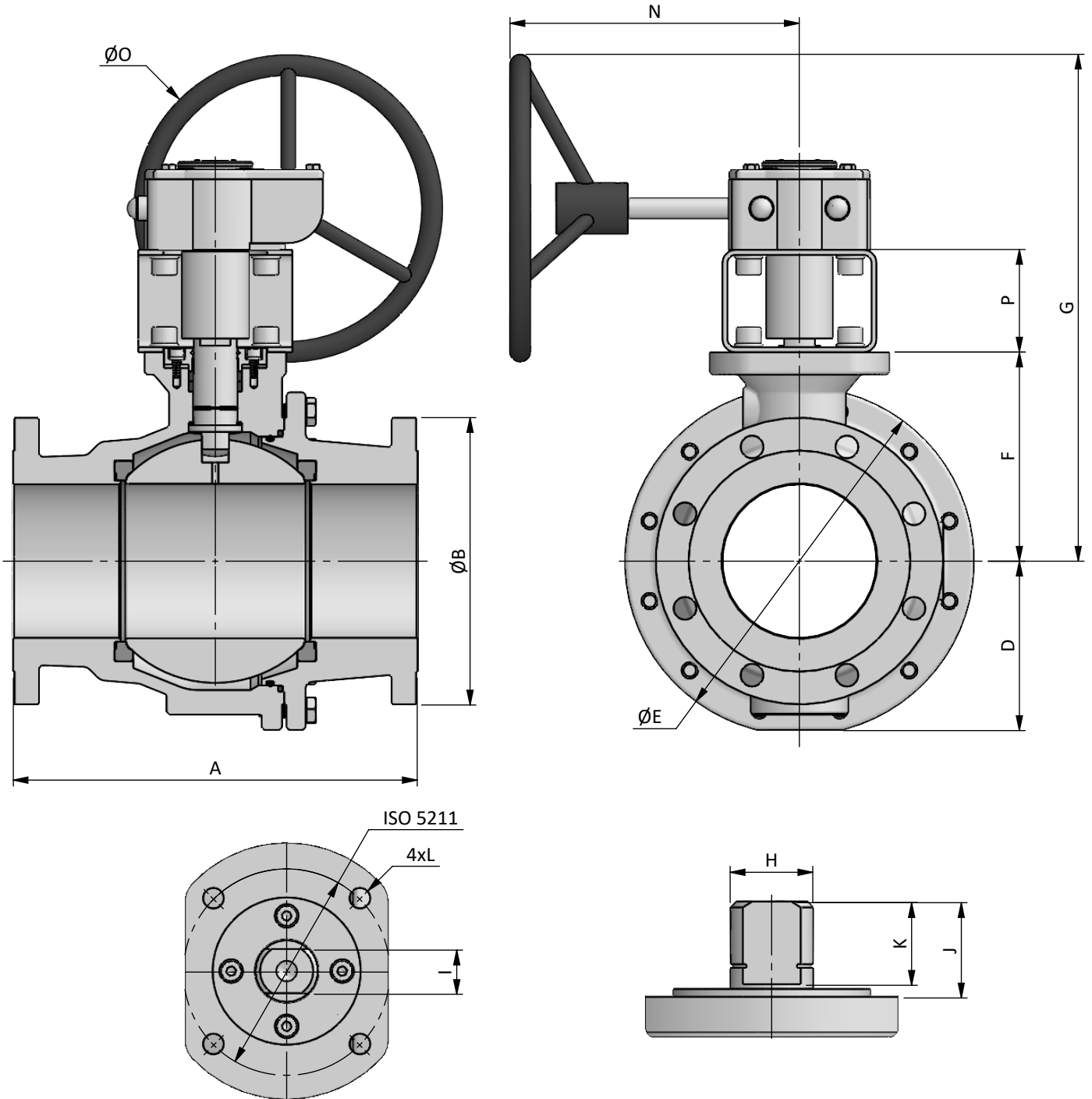
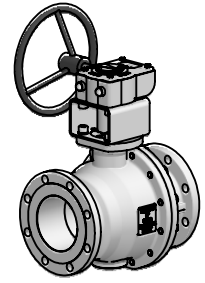

DN / Size		Dimensions										Automation							Weight Approx. [Kg]			
FULL BORE		Ball Port	PN	F#		F5		D	E	F	G	H	I	J	K	L	N	O	P	ISO 5211	F#	F5
mm	inch			A	B	A	B															
150	6"	151	16	-	-	350	285	165	340	205	495	42	30	48.5	28.5	M16	285	300	100	F14	-	105
200	8"	202		-	-	400	340	215	440	260	600	56	36	70	65	M20	285	400	100	F16	-	195
150	6"	151	40	403	300	-	-	170	350	205	495	42	30	48.5	28.5	M16	285	300	100	F14	110	-
200	8"	202		502	375	-	-	220	450	260	615	56	36	70	65	M20	330	400	100	F16	200	-

F# - FTF = CL300

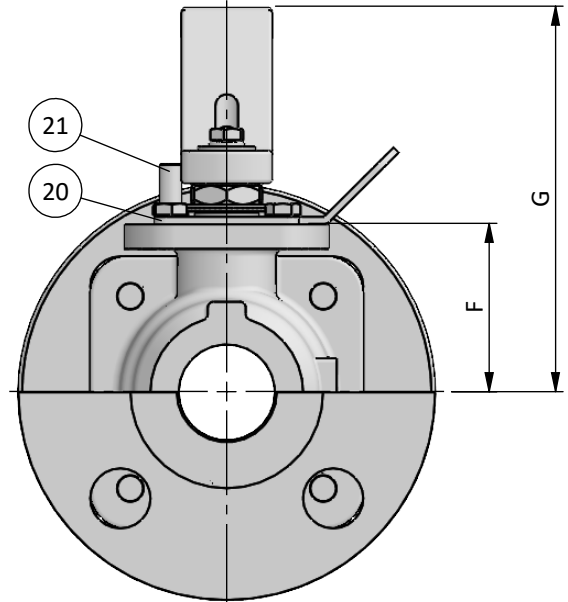
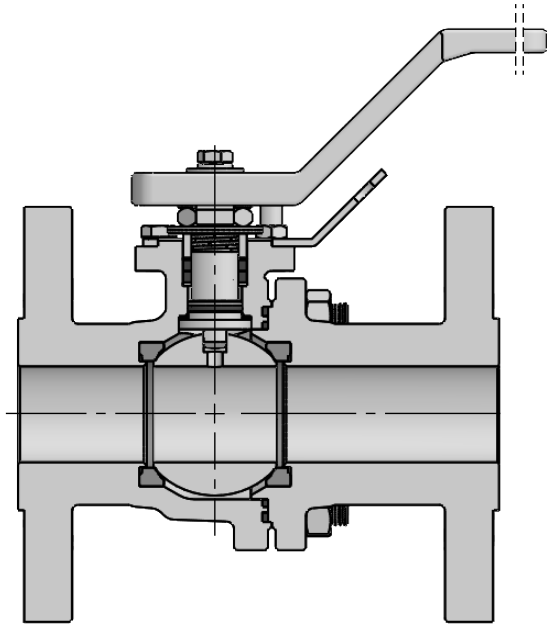
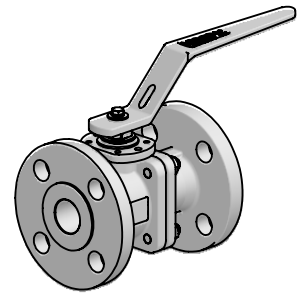

**BILL OF MATERIALS**

Part	Qt.	Description	Material
20	1	Locking Plate	STAINLESS ST. 304
21	1	Stop Pin	STAINLESS ST. 316

DN / Size		Dimensions	
FULL BORE		F	G
mm	inch		
15	½"	35	90
20	¾"	40	100
25	1"	45	105
32	1¼"	55	125
40	1½"	60	125
50	2"	80	150
65	2½"	95	175
80	3"	105	190
100	4"	135	225
150	6"	GEARBOX	
200	8"		

## CFH SERIES

PN16/PN40  
FULL BORE - DN015 (½") ÷ DN200 (8")  
STANDARD DIN  
BRACKET FOR AUTOMATION

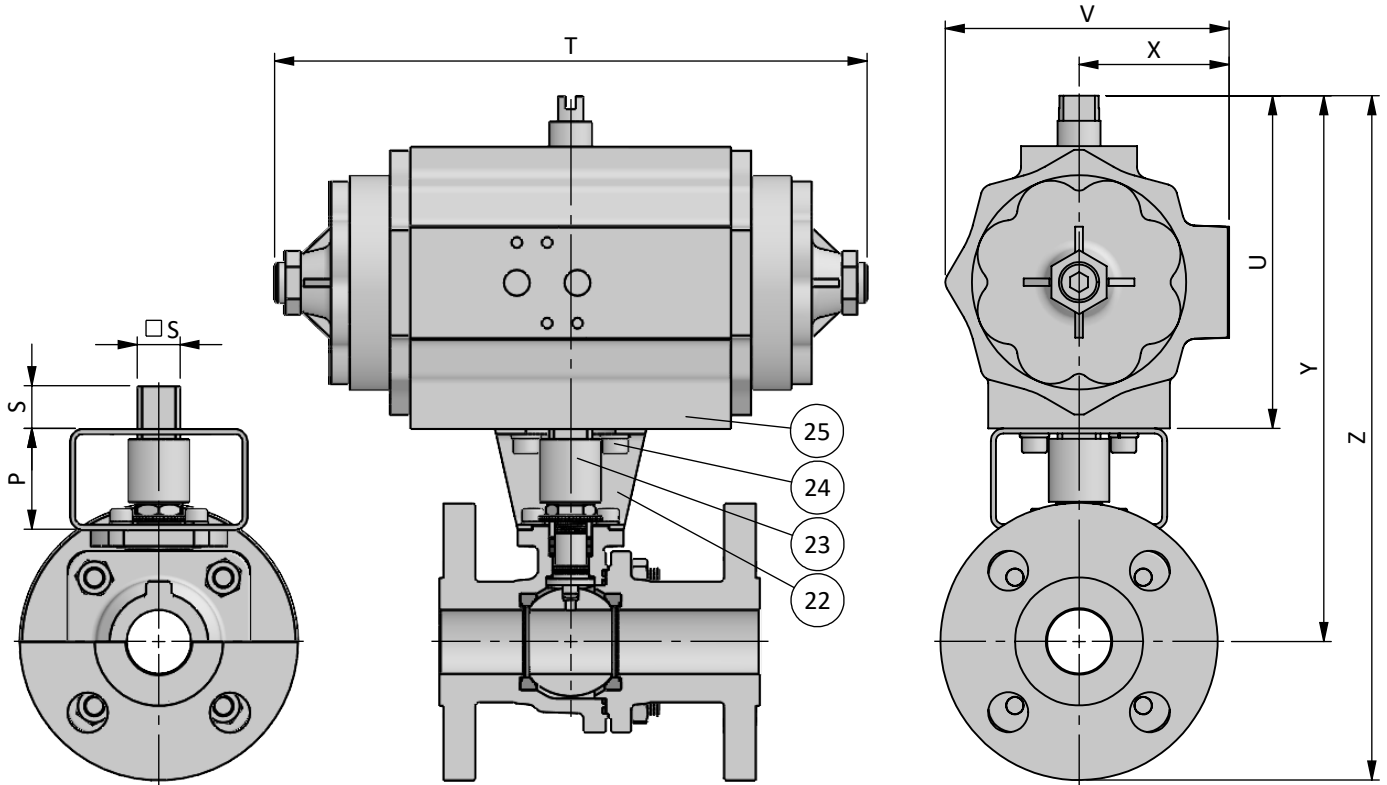
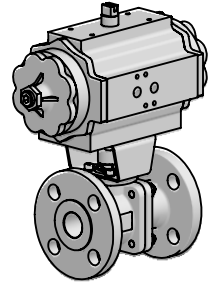

### BILL OF MATERIALS

Part	Qt.	Description	Material
22	1	Bracket	STAINLESS ST. 304
23	1	Coupling	A479 316/L
24	8	Bolt	STAINLESS ST. 316
25	1	Actuator	ALUMINIUM

DN / Size		Automation		Actuator*							Automation		Actuator*						
FULL BORE		P	S	PN16							P	S	PN40						
mm	inch			REF.	T	U	V	X	Y	Z			REF.	T	U	V	X	Y	Z
15	½"	40	11	-	-	-	-	-	-	-	40	11	005-10	180	111	89	49	190	235
20	¾"	40	11	-	-	-	-	-	-	-	40	11	005-10	180	111	89	49	195	245
25	1"	40	17	-	-	-	-	-	-	-	40	17	008-10	233	131	112	57	220	275
32	1¼"	50	17	-	-	-	-	-	-	-	50	17	008-10	233	131	112	57	235	305
40	1½"	50	19	-	-	-	-	-	-	-	50	19	012-08	280	131	112	57	240	315
50	2"	60	22	-	-	-	-	-	-	-	60	22	020-14	294	151	133	70	290	375
65	2½"	60	22	030-18	286	189	169	85	345	435	60	22	030-18	286	189	169	85	345	435
80	3"	100	22	030-18	286	189	169	85	395	495	100	27	040-18	344	199	169	85	405	505
100	4"	100	27	040-18	344	199	169	85	435	550	100	36	100-18	440	246	210	108	480	600
150	6"	100	46	200-20	537	272	232	120	580	720	100	36	250-40	460	340	305	151	645	805
200	8"	100	46	370-20	670	340	305	151	700	870	under request								

\*Spring Return Pneumatic Actuators selected for PTFE and filled PTFE seats considering input air pressure of 5.5bar and minimum 25% safety margin

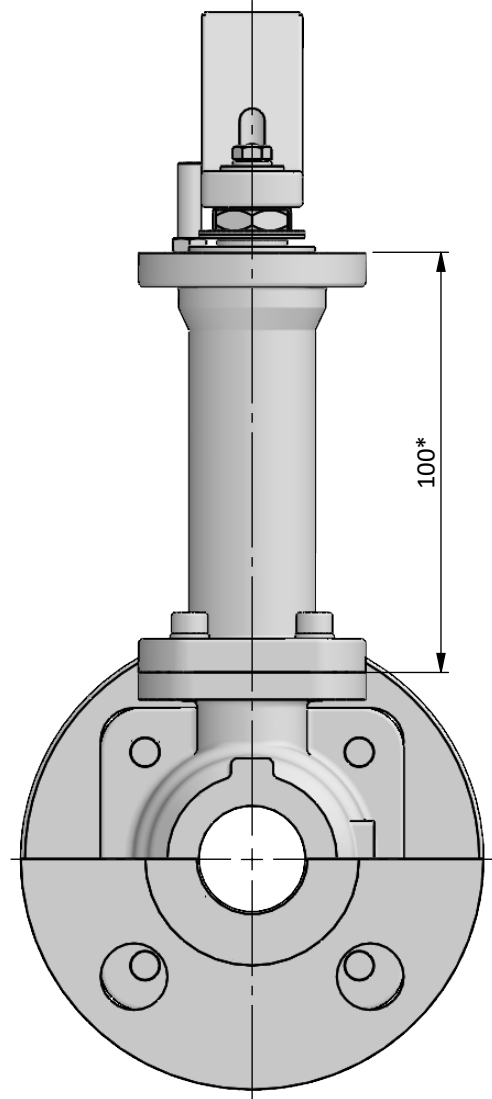
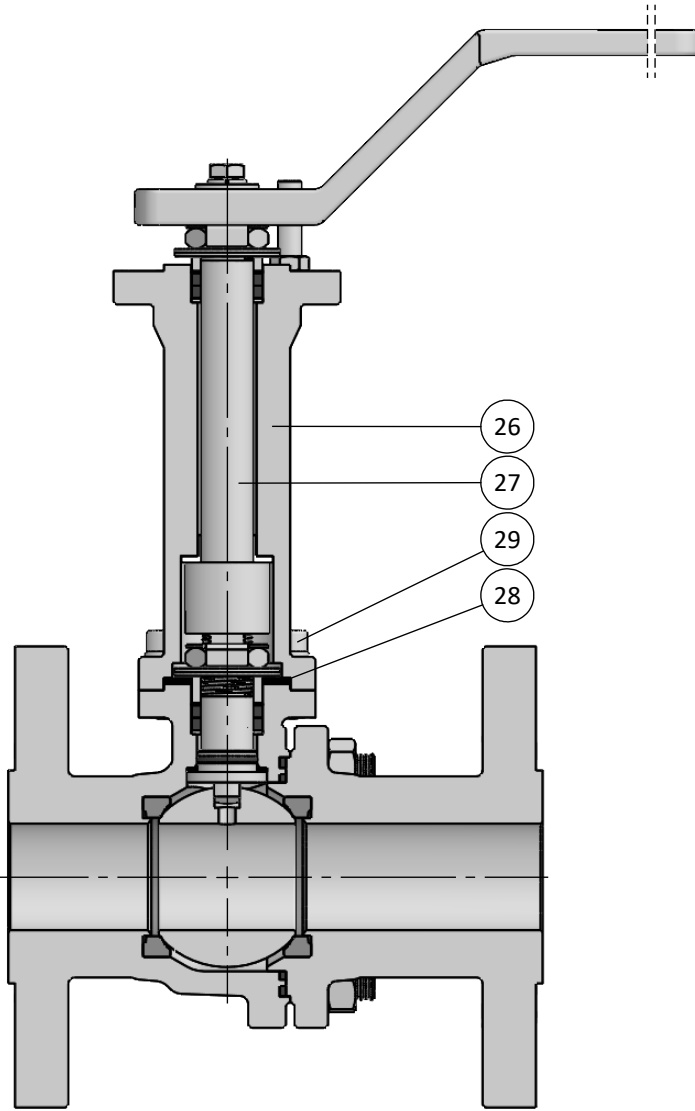
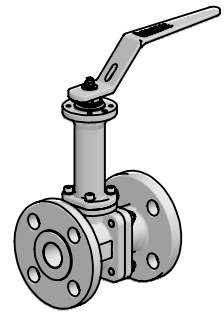

**BILL OF MATERIALS**

Part	Qt.	Description	Material
26	1	Extension	A351 CF8M
27	1	Stem	A479 316/L
28	1	Extension Seal	GRAPHITE
29	4	Bolt	STAINLESS ST. 316

\* Size 6" and 8" valve extension height is 150mm and 200mm

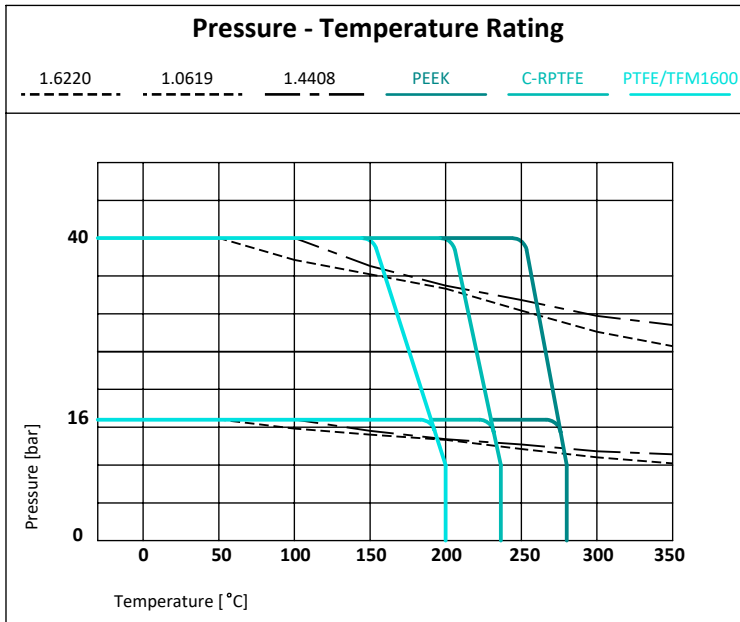

Working Conditions					
Material	mOT* [ °C]				MOT* [ °C]
	1.0619	1.6220	1.4408	ALL	
PTFE TFM1600	-29	-46	-50	-100*	200
C-RPTFE	-29	-46	-50	-100*	240
PEEK	-29	-46	-50		280

\*mOT - minimum Operating Temperature.  
\*MOT - Maximum Operating Temperature at 10 bar  
Standard version recommended up to -50 °C  
\*Extended version recommended up to -100 °C

DN	Rating
FB 15 (½") to 200 (8")	PN40 - 40 bar
FB 65 (2½") to 200 (8")	PN16 - 16 bar

DN / Size		Torque Valve Figure [Nm] *												Maximum Allowable Stem Torque [Nm]					Flow Coefficient Cv
FULL BORE		C-RPTFE												316	S31803	S32760	S17400	718	
		PN16						PN40						MAST					
mm	inch	BTO	RTO	ETO	BTC	RTC	ETC	BTO	RTO	ETO	BTC	RTC	ETC						
15	½"	-	-	-	-	-	-	7	4	6	6	4	6	16	25	30	40	53.5	20
20	¾"	-	-	-	-	-	-	10	6	8	8	6	8	29.5	45	55	71.5	98.5	45
25	1"	-	-	-	-	-	-	14	8	11	11	8	12	29.5	45	55	71.5	98.5	75
32	1¼"	-	-	-	-	-	-	21	12	16	16	12	17	82.5	125	150	200	275	175
40	1½"	-	-	-	-	-	-	29	16	22	22	16	24	82.5	125	150	200	275	175
50	2"	-	-	-	-	-	-	40	22	30	30	22	32	110	240	290	385	535	300
65	2½"	58	32	44	44	32	47	65	36	49	49	36	52	205	445	540	715	1000	500
80	3"	70	39	53	53	39	56	80	44	60	60	44	64	205	445	540	715	1000	1000
100	4"	110	61	83	83	61	88	170	94	128	128	94	136	405	880	1075	1420	1950	2000
150	6"	350	193	263	263	193	280	500	275	375	375	275	400	1150	2525	3085	4075	5600	4500
200	8"	850	468	638	638	468	680	1650	908	1238	1238	908	1320	2530	5550	6800	8950	12350	10000

\*Values without safety margin

Reference BTO 100% - RTO 55% | ETO 75% | BTC 75% | RTC 55% | ETC 80%

CERTIFICATION	CONSTRUCTION STANDARDS	TEST STANDARDS
CE Certification acc. to PED 2014/68/EU Fire Safe Design acc. to API 607Ed.6/ISO 10497 ATEX II 2GD acc. to 2014/34/EU Fugitive Emissions Class B acc. to ISO 15848 CO1 (-46 °C to RT) Quality System Certified acc. to ISO 9001	ISO 17292 DIN EN 1092-1 EN 558-1 ISO 5211	Pressure tests according to: EN12266-1 / API 598 / ISO 5208 Rate A  Tests applied: Hydrostatic Shell Test Hydrostatic Seat Test Pneumatic Tightness Test Pneumatic Seat Test  EN 10204 type 3.1 Certificate

Standards acc. to the latest available revision

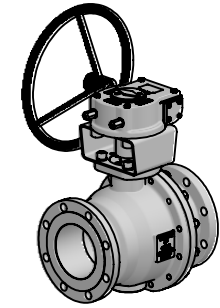
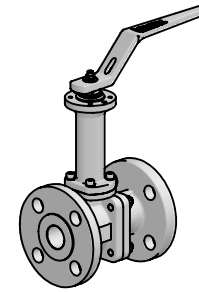
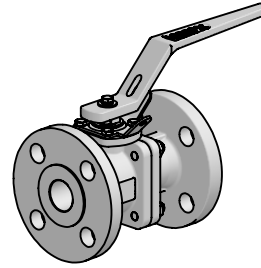
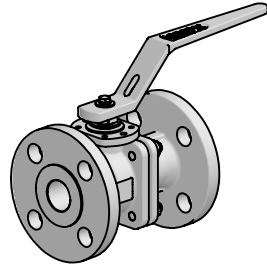

SERIE	CLASS	VERSION	PORT	DN	ENDS	BODY	BALL   STEM	BOLTING	SEATS   1ª SEAL	PACKING   2ªSEAL   O'RING	OPTIONS
CFH	1 - PN16 2 - PN40	6 - DIN	F - FB	015	FLANGED RF	A - 1.0619	F - A351 CF8M   A479 316	A - 8.8	3 - C-RPTFE   C-RPTFE	1 - Grafite   Grafite   FKM AED	C - Spring Return
				020	F2 - DIN F4	B - 1.6220	Z - Others	F - A4 CL70	E - Extension 100 mm		
				025	F3 - DIN F1	F - 1.4408	F - Bracket Automation				
				032	Z - Others	G - Gear Box					
				040	H - Actuators						
				050	I - Switch Box / Limit Swiches						
				065	L - Locking Lever/Handle						
				080	O - Oval Lever/Handle						
				100	R - Bare Shaft / Bare Stem						
				150	S - Solenoid Valve						
200	T - Upstream Relief Hole										
										W - "V" Ball Port	
										Z - Others	

Example:

CFH26F015F2F2AFA41

CFH16F080F3F3FFF41L

## HYDROGEN RANGE

CFH Series  
2 split body - Floating  
CI 150/300  
DN ½" (15) to 8" (200)



XFH Series  
3 pieces bolted - Floating  
CI 300 to 600  
DN ¾" (10) to 6" (150)



SFH Series  
3 pieces bolted - Floating  
CI 800  
DN ½" (15) to 1½" (40)



HFH Series  
3 pieces bolted - Floating  
CI 1500  
DN ½" (15) to 2" (50)



HFH Series  
3 pieces bolted - Floating  
CI 2500  
DN ½" (15) to 1" (25)



HFH Series  
3 pieces bolted - Floating  
CI 4000  
DN ½" (15) to 1" (25)



## OTHER RANGE

SANITARY RANGE  
XP / RP / LP / MP / QP



CRYOGENIC RANGE  
CCF / CXF / CBF / CSF / CVT



METALLIC SEATS RANGE  
XFM / CFM / BFM / SFM / VTM



